

OCS 240/241 **Chlorine Dioxide Measuring Cell**

Operating Instructions

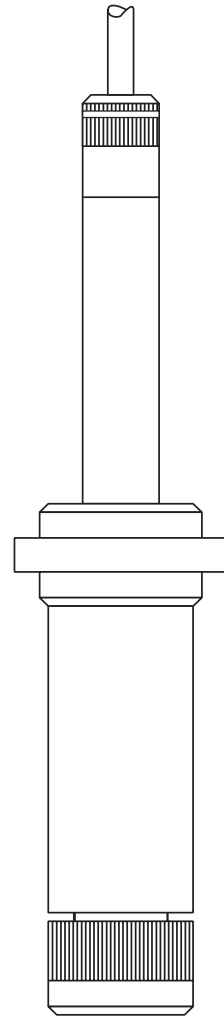

Table of contents

1	General information	2
1.1	Symbols used	2
1.2	Safety notes	2
1.3	Conformity statement	2
1.4	Unpacking	3
1.5	Scope of delivery	3
1.6	Ordering system	3
2	Description	4
2.1	Areas of application	4
2.2	Dimensions	4
2.3	Measuring system	5
2.4	Constructions of measuring cells	6
2.5	Operating principle	7
2.6	Influences on the measuring signal	7
3	Mounting and installation	8
3.1	Installation in flow assembly OCA 250	8
3.2	Installation in other flow assemblies	8
4	Start-up and calibration	9
4.1	Connection to the measuring transmitter	9
4.2	Polarisation	9
4.3	Reference measurement according to the DPD method	9
4.4	Calibration	10
5	Operation and maintenance	11
5.1	Routine check	11
5.2	Membrane replacement	11
5.3	Filling with electrolyte	11
5.4	Storage	11
5.5	Regeneration	11
6	Troubleshooting	12
7	Appendix	14
7.1	Technical data	14
7.2	Accessories	14
7.3	Index	15

1 General information

1.1 Symbols used

**Warning:**

This symbol alerts to hazards which may cause serious personal injuries or material damage.

**Caution:**

This symbol alerts to possible malfunction due to operator error.

**Note:**

This symbol indicates important items of information.

1.2 Safety notes

The intended use is described in these operating instructions.

**Warning:**

- Operating the device in a manner other than as described in these instructions may compromise the safety and function of the sensor and connected systems and is therefore impermissible.
- Connection and maintenance work on the device must be carried out by trained personnel.
- Repair work must be carried out directly by the manufacturer or by an authorised service organisation. Interventions in or changes to the device except for required maintenance work according to the operating instructions are impermissible and will void the warranty.
- The operator is liable for the observance of local safety regulations.

1.3 Conformity statement

The chlorine measuring cells OCS 240/241 have been developed in accordance with the applicable European standards and directives and are subject to corresponding manufacture.

**Note:**

The corresponding certificate of conformity may be requested from your sales agency.

1.4 Unpacking

- Verify that the contents are undamaged. Inform the post office or freight carrier as well as the supplier of any damage.
- Check that the delivery is complete and agrees with the shipping documents and your order (see chapter 1.5).
- Save the original package in case the device must be stored or shipped at a later time.
 - Quantity delivered
 - Unit type and version according to nameplate
 - Operating instructions

If you have any questions, please consult your supplier or the sales office in your area (see back cover of these Operating Instructions).

1.5 Scope of delivery

The delivery comprises:

- 1 chlorine dioxide measuring cell OCS 240 or OCS 241
- 1 cap for membrane protection or for storage
- 50 ml of spare electrolyte in a squeeze bottle
- 1 spare cartridge with pretensioned membrane
- 1 Operating Instructions

To facilitate distinction, the measuring cell types are equipped with a rating plate and a colour-coded ring on the cable gland:



Caution:

- Chlorine dioxide measuring cell OCS 240: **green ring**
- Chlorine dioxide measuring cell OCS 241: **yellow ring**

1.6 Ordering system

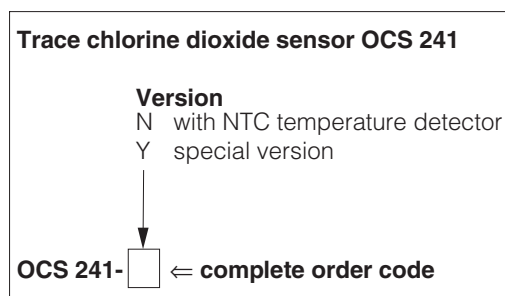
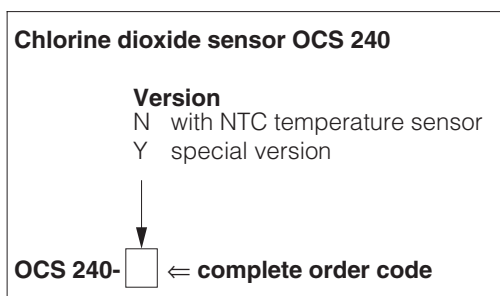

2 Description

2.1 Areas of application

Drinking water, water for industrial/domestic use and bath water must be sterilised by the addition of appropriate disinfectants such as gaseous chlorine or inorganic chlorine compounds. At the same time, the dosages must be adapted to the constantly changing operating conditions. Too low concentrations in the water jeopardise successful disinfection, while too high concentrations may not only result in superfluous expenditure but may also cause corrosion and detrimentally affect taste.

The chlorine measuring cell OCS 140 or 141 has been specially developed for this purpose and enables continuous measurement of the freely active chlorine content. When used in connection with a measurement and control system, it permits the required optimum disinfection status to be maintained.

sensor	%Measuring range [mg ClO ₂ /l]
OCS 240	0.05 ... 20.00 (e.g. pool water)
OCS 241	0.01 ... 5.00 (ze.g. drinking water)



Caution:

Perfect operation of the measuring system requires the following operating conditions:

- Constant pH value after chlorine calibration (see chapter 2.6). Not required for measurement in the “pH compensated” mode of operation.
- Constant temperature after chlorine calibration, except for ATC option (see chapter 2.6). Not required for measurement in the “temperature compensated” mode of operation.
- Minimum flow rate of measured water 30 l/h (red bar mark when using the flow assembly OCA 250, see chapter 2.6 and operating instructions OCA 250, no. 50036190).
- No use of organic chlorination agents (see chapter 4.3).

2.2 Dimensions

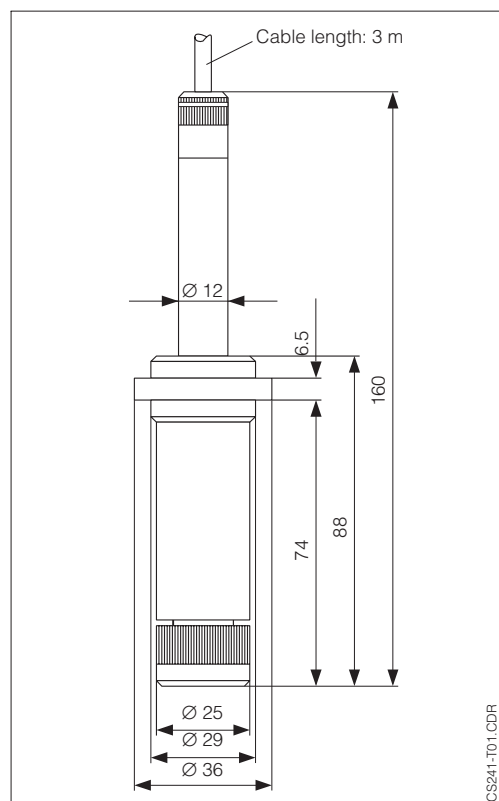
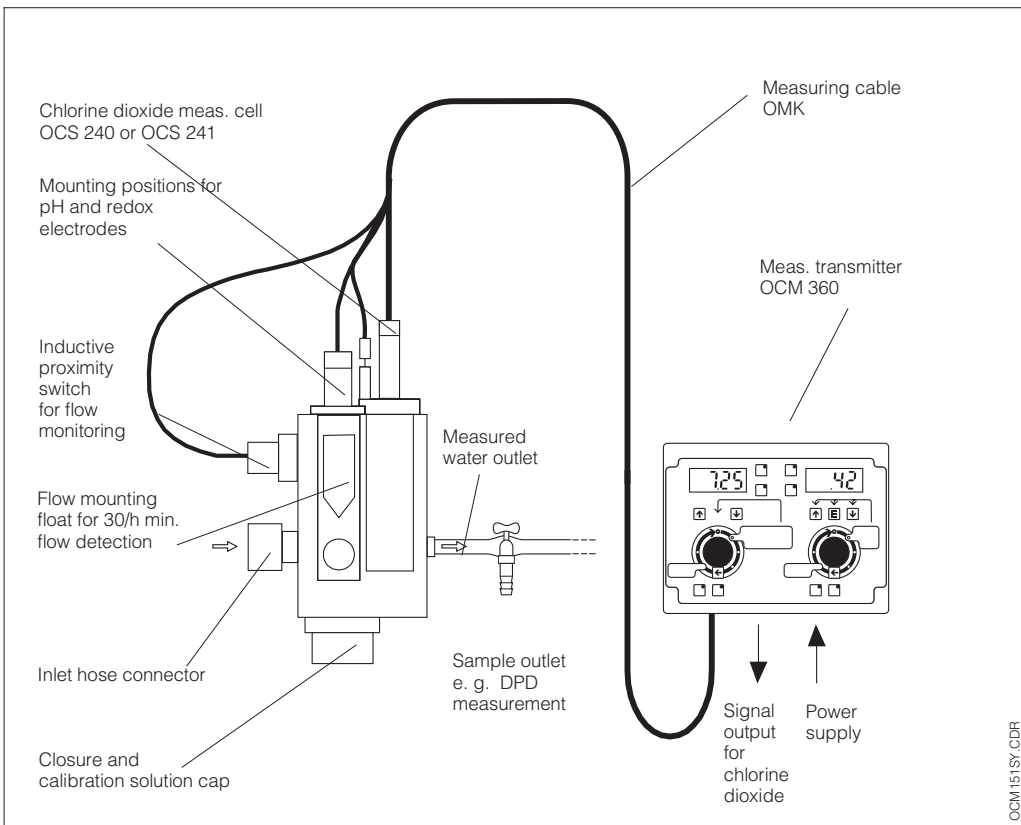

Fig. 2.1 Dimensions of OCS 240 / OCS 241

2.3 Measuring system

The complete measuring system comprises:

- Chlorine dioxide measuring cell OCS 240 or OCS 241
- Measuring transmitter OCM 360
- Measuring cable OCK (order no. 51500490) for connecting the chlorine measuring cell to the measuring transmitter (only if cable extension is required)
- The maximum line length is 30 m
- Flow assembly OCA 250
- Measuring instrument to determine the reference value according to the DPD method, e.g. microprocessor photometer OCM 181



Complete measuring system, e. g. with OCM 360 transmitter, OCA 250 assembly, pH, ORP and chlorine dioxide sensor and proximity switch INS
 Fig.2.2

2.4 Constructions of measuring cells

The chlorine measuring cell OCS 240 or OCS 241 is easy to handle and can be dismantled into components for filling, to replace the diaphragm or for regeneration (see fig 3.1).

The measuring electrodes are located in a measuring chamber sealed off from the measured medium, separated by a PTFE membrane which is extremely resistant both chemically and mechanically.

The gold cathode, embedded in plastic, and the silver / silver chloride anode are situated at the lower end of the shaft piece with the connection cable. A special support grid between gold cathode and PTFE membrane maintains a specified spacing thus ensuring

A constant electrolyte film with the advantage of a relatively constant indication even for varying pressures or flows. A long service life is achieved by the large electrolyte volume combined with a large anode surface and a small cathode surface. The membrane cap can be replaced after removal of the screw cap.

Version with temperature sensor (OCS 240-N or OCS 241 N)

An NTC temperature sensor is embedded in the lower third of the shaft. This allows an automatic compensation of the temperature dependence of the measuring signal and additionally an indication of the measured water temperature

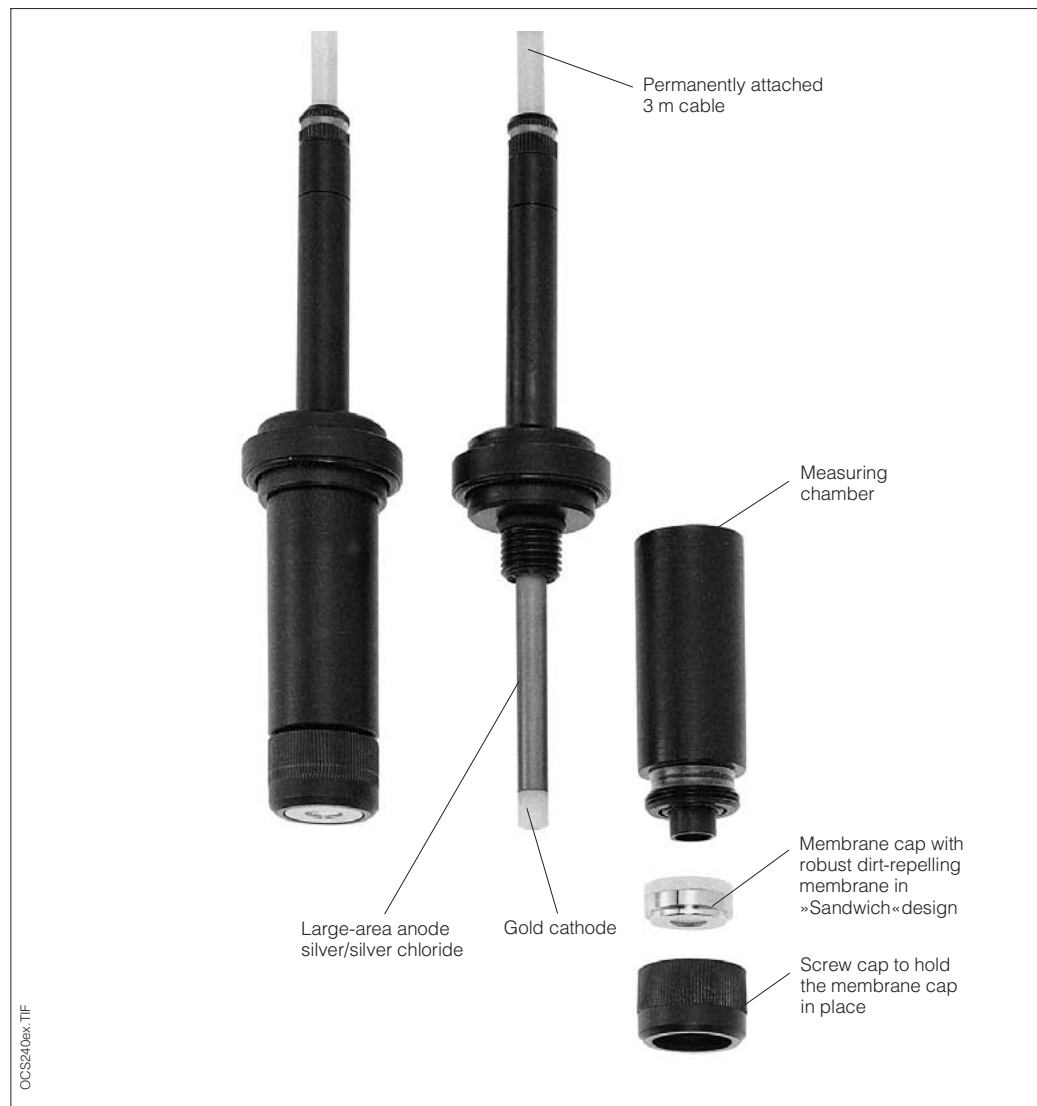

Chlorine dioxide meas. cell
OCS 240 or OCS 241:
Ready to operate and
dismantled

Fig.2.3

2.5 Operating principle

When a measuring cell is connected to the corresponding measuring transmitter, a fixed external voltage is applied to the electrodes. Due to the difference in electrode area, this results in a polarisation at the gold cathode. The polarisation current generated during polarisation is visible on the measuring transmitter by very high display values which decrease over time and eventually stabilise. Polarisation must be complete before the measuring cell can be calibrated.

Chlorine dioxide is present in the medium as a physically dissolved gas and is transported towards the membrane by the medium flow which is required for measurement. The membrane materials assure that only dissolved gases but no liquid-phase constituents can pass through the membrane. Dissolved salts and ionic substances are also held back. This is the reason why - contrary to the open measuring principle - the conductivity of the medium does not influence the measuring signal.

The chlorine dioxide diffusing through the membrane is reduced to chloride ions at the gold cathode while silver is oxidised to silver chloride at the anode. The related electron release at the cathode and electron acceptance at the anode cause a current flow which - under constant conditions - is proportional to the external concentration of chlorine dioxide in the medium. Due to this measuring principle, the chlorine dioxide measuring cells described here are termed to be **amperometric**. The current flow is converted in the measuring transmitter and shown on the display as the dissolved chlorine dioxide concentration in mg/l.

2.6 Influences on the measuring signal

Flow rate

The membrane-covered measuring cell requires a minimum flow velocity of 15 cm/s in order to function. When using the flow assembly OCA 250, this value corresponds to a flow rate of 30 litres per hour (upper edge of float at level of red bar mark). The measuring signal is virtually flow-independent at more elevated flow rates while a flow dependence exists for flow velocities lower than the value mentioned above. When an INS proximity switch is installed in the assembly, insufficient flow rates can be reliably detected, and an alarm signal can be issued, e.g. to disable chlorine dioxide proportioning.

Free chlorine

Since chlorine dioxide is explosive when mixed with air, it must be produced directly at the place of intended use. It can be obtained by means of two different methods: The sodium chlorite-hydrochloric acid process which results in solutions which are practically free of chlorine, and the sodium chlorite-chlorine gas method which may also produce free chlorine besides chlorine dioxide, depending on the system parameters. In the second case, the cross-sensitivity of the chlorine dioxide measuring cells to free chlorine is approx. 5 % of the DPD 1 value for free chlorine alone at 25 °C and pH 7.2.

Temperature

Changes in the medium temperature affect the measuring signal. An increase in temperature increases the measured value and lower temperatures result in lower measured values. The temperature sensor built into the measuring cell measures the medium temperature, permitting the measuring transmitter to perform a temperature compensation of the measured value display within the permissible temperature range.

3 Mounting and installation

3.1 Installation in flow assembly OCA 250

The flow assembly OCA 250 is intended for installation of the measuring cell in the field. This assembly will hold a pH and a redox electrode in addition to the chlorine dioxide measuring cell. A needle valve regulates the flow rate in the range from 30 to 120 l/h. Flow rates below 30 l/h or total loss of flow can be detected by installing an inductive proximity switch (-INS option, order no. 50005179). The resulting signal can be used to issue an alarm and disable chlorine dioxide metering if necessary. The chlorine dioxide measuring cell is installed in the flow assembly by means of the union nut (refer to the operating instructions supplied with the flow assembly for detailed notes on installation).



Warning

When the assembly is operated under pressure, the counterpressure on the measuring cell generated on the outlet side must not exceed 1 bar and must remain constant.

3.2 Installation in other flow assemblies

When other assemblies are to be used, a minimum flow velocity of 15 cm/s at the membrane must be guaranteed at all times. The measuring cell is to be installed such that the medium flows from the bottom to the top in order to assure removal of air bubbles contained in the medium, preventing them from collecting at the membrane. The medium flow should be directed directly towards the membrane.

4 Start-up and calibration

4.1 Connection to the measuring transmitter

Note the following cable assignments when connecting the measuring cell:

Cable	Colour / marking	Assignment
Coaxial inner conductor	transparent / "K"	gold cathode
Coaxial screen	red / "A"	silver / silver chloride anode
Auxiliary cores	green, brown	NTC temperature sensor (connection polarity free)

4.2 Polarisation

The voltage applied between the cathode and anode by the measuring transmitter polarises the cathode surface.

Times required for polarisation

- First start-up:
30 minutes (OCS 240)
90 minutes (OCS 241)
- Subsequent start-up:
10 minutes (OCS 240)
45 minutes (OCS 241)



Note:

Calibration can only be performed upon expiration of the periods listed above.

4.3 Reference measurement according to the DPD method

The calibration of the measuring system requires a colorimetric reference measurement according to the DPD method. Free chlorine reacts with diethyl-p-phenylenediamine (DPD) by producing a red dye, the intensity of the red colour being proportional to the chlorine concentration.

Simple visual methods using comparators are inaccurate and depend on the considerably varying subjective evaluation by the operator. Today, the chlorine concentration can be determined objectively and accurately using low-cost microprocessor photometers (order code OCM 181).

An important fact must be kept in mind: The DPD method is not a selective measuring method for free chlorine alone, but other oxidants present in the medium can also be registered (see DIN 38408, part 5, section 4). Moreover, the measuring range of the photometers has a lower limit and does not

permit measurements in the very low trace range. In addition to the chlorinated probe, a sample of the medium without added chlorine should be checked by a DPD measurement if possible. The measured value must lie near zero and differ significantly from the chlorinated sample.

The measured water is always buffered to a pH value of 6.3 with the DPD method, so the measurement is independent of the pH value of the measured water.



Caution:

The DPD method cannot be applied if organic chlorination agents are used. In this case it causes a higher measured value compared to the actual free active chlorine value (cf. also note in DIN 38408, part 4, section 5).

4.4 Calibration

Zero adjustment

Not required due to the zero stability of the membrane-covered measuring cell.

Slope adjustment (sensitivity)

- Ensure constant operating data of the measured water regarding pH value and temperature.
- Read the current chlorine dioxide value from the transmitter display. Then take a medium sample from the sampling cock immediately.
- Use the photometer to determine the chlorine dioxide concentration according to the DPD method.
- Set the measuring transmitter to the determined DPD value if there is a difference from the read actual value.
- Check calibration after several hours or one day and repeat it if required.

5 Operation and maintenance

5.1 Routine check

- Check the measurement at regular intervals, dependent on the respective conditions, at least once a month.
- Perform recalibration if required.
- If the membrane is visibly soiled, remove the measuring cell from the flow assembly. Only clean the membrane mechanically with a gentle water jet or for some minutes in 1 to 10% hydrochloric acid (observe safety regulations!) without chemical additives. Chemicals reducing the surface tension must not be used.
- Replace a heavily soiled or damaged membrane (see chapter 5.2).
- Refill the measuring cell with electrolyte once per season or every 12 months. Depending on the chlorine content on site, this period can be reduced or extended (procedure see chapter 5.3).

5.2 Membrane replacement

Replacement of a heavily soiled or leaky membrane:

- First unscrew the measuring chamber, then the front screw cap (see Bild 2.3).
- Replace the membrane cap by the replacement cartridge CCY 14-WP.
- Refill the measuring chamber with electrolyte CCY 14-F (see chapter 5.3).

5.3 Filling with electrolyte

To replace the electrolyte CCY 14-F, proceed as follows:

- Unscrew the measuring chamber from the shaft.
- Hold the measuring chamber at an angle and fill in approx. 7 to 8 ml electrolyte, up to approx. 1 cm under the top edge.
- Tap the filled chamber several times on a flat surface, so that adherent air bubbles can detach and rise.
- Screw the electrode shaft into the measuring chamber vertically from above, ensuring that all inside air is displaced.
- As soon as the inserted O-ring begins to seal, tighten slowly to the stop.
- The measuring cell is now ready for operation.

5.4 Storage

When not in use, the measuring cell should be stored as follows:

- In the case of short-term interruptions in operation, the measuring cell can remain in the flow assembly. In order to prevent the membrane from drying out, the assembly must never be empty of medium. If this cannot be guaranteed, the measuring cell must be removed from the assembly. To keep the membrane moist, moisten the sponge inside the protection cap with electrolyte and insert the protection cap on the measuring chamber.
- If the measuring cell will not be in use for an extended period, in particular if it is likely to dry out, the measuring cell must be emptied. To clean, rinse the measuring chamber and electrode shaft with cold water and allow to dry. Then screw the measuring cell closed only loosely (not all the way to the stop) to leave the membrane relaxed. Proceed according to section 6.2 to return the measuring cell to use.

5.5 Regeneration

The electrolyte filling in the chlorine dioxide measuring cell is used up slowly during measurement due to chemical reactions.

The silver chloride coating on the anode applied at the factory continues to grow during the operation of the measuring cell. This has no influence on the reaction taking place at the cathode. Indications for regeneration are sluggish measured value display and slope adjustments that can only be performed with

difficulty or not at all. The time intervals between regeneration depend on the chlorine dioxide concentration in the medium, where higher concentrations require more frequent regeneration. When the measuring cell is used in water with an average chlorine dioxide concentration, the measuring cell will operate properly for many years. If the measuring cell requires regeneration, it must be returned to the manufacturer.

6 Troubleshooting

Problems are basically possible in three areas of the measuring system:

- Measuring transmitter
- Cables and connections
- Chlorine dioxide measuring cell and medium

Measuring transmitter, cable and connection problems should always be eliminated first.

In this case, refer to the installation and operating instructions of the measuring transmitter for troubleshooting.

If the problem cannot be eliminated, proceed with the following troubleshooting chart.

Problems	Possible cause	Remedy
No display Measuring cell does not respond	Measuring transmitter is not supplied with power	Establish mains connection
	Break in line from the measuring cell to the measuring transmitter	Establish cable connection
	No electrolyte in measuring chamber	Fill measuring chamber (see section 6. 2)
	No medium flow	Establish medium flow, clean filter
Display value too high	Measuring cell not completely polarised	Wait for polarisation to complete (section 5.2)
	Membrane defective	Replace membrane cap
	Shunt (e.g., moisture bridge) in the measuring cell, at the connections or in the connecting cable	Open measuring chamber. Rub gold cathode dry. A shunt exists if the transmitter display does not return to zero
	Interference by foreign oxidizing agents	Check medium, check chemicals

Problems	Possible cause	Remedy
Display value too low	Measuring chamber not screwed all the way tight	Screw on measuring chamber or screw cap completely
	Membrane soiled	Clean membrane
	Air bubble on outside of membrane	Eliminate air bubble
	Air bubble inside between cathode and membrane	Open measuring chamber, fill in some electrolyte, knock
	Medium flow insufficient	Richtige Anströmung Establish required flow rate
	DPD measurement is rendered inaccurate by foreign oxidizing agents	Check medium, check chemicals
Display value fluctuates considerably	Hole in membrane	Replace membrane cap
	External voltage in medium	Disconnect wire from PMC pin on CCA 250 assembly. Measure voltage between PMC pin and protective ground (AC and DC ranges). Locate external voltage source and eliminate if values exceeding a few volts are measured
Temperature display – too high – too low	NTC thermistor line: – break – short circuit	Test wires (green/brown) and measure resistance (NTC), replace measuring cell if necessary

7 Appendix

7.1 Technical data

		OCS 240	OCS 241
Measuring range		0.05 ... 20 mg ClO ₂ /l	0.01 ... 5.00 mg mg/ClO ₂ /l
Polarisation period	first polarisation	up to 30 min	up to 90 min
	Subsequent polarisation	up to 10 min	up to 45 min
Drift		< 1,5 % per month	
Response time after sudden change in measured value		90 % < 2 min, 99 % < 5 min	
Minimum flow for CCA 250 assembly		30 l/h	
Minimum flow velocity		15 cm/s	
Permissible temperature range		2 ... 45 °C	
Maximum counterpressure		1 bar	
Average life of filling electrolyte		typ. 12 months	
Temperature sensor		NTC, 10 kOhm at 25 °C	
Measuring system		passively operated measuring cell with gold cathode and silver/silver chloride anode	
Shaft material		PVC	
Membrane material		PTFE	
Membrane cap		replaceable	
Cable connection		low-noise, four-wire cable, length 3 m dual screen, transparent, „K“: gold cathode red, „A“: silver/silver chloride anode green/brown: NTC thermistor detector wire mesh: outer screen	
Temperature sensor (-N version)		NTC, 10 kΩ at 25 °C	

7.2 Accessories

Measuring cable OCK

Special measuring cable for extension of the connection between chlorine sensor and measuring instrument.
Order no. 51500490

Junction box VBC

Installation box for measuring cable extension up to max. 30 m total length.
Dimensions (W × H × D): 125 × 80 × 54 mm
Order no. 5000518

OCY 14-WP

2 ready-made spare cartridges for cells OCS 240/241
Order no. 51500461

OCY 14-F

50 ml filling electrolyte for cells OCS 240/241
Order no. 51500462

7.3 Index

A		O	
Accessories	14	Operating and maintenance	11
Anode	6	Operating conditions	4
Appendix	14-15	Ordering system	3
Areas of application	4	Organic chlorination agents	4, 9
		Other flow assemblies	8
C		P	
Cable assignments	9	Package	3
Calibration	10	pH value	4
Cathode	6	Polarisation	9
OCY 14-F	14	Polarisation period	14
OCY 14-WP	14	Problems	12
Chlorination agents, organic	4, 9	PTFE membrane	6
Cleaning of the membrane	11		
Conformity statement	2	R	
Connection to the measuring transmitter	9	Recalibration	11
Constructions of measuring cells	6	Reference measurement	9
		Refilling with electrolyte	11
D		Regeneration	11
Description	4-7	Repair	2
Dimensions	4	Response time	14
Disinfection	4	Routine check	11
DPD method	9		
		S	
E		Safety notes	2
Electrolyte	11	Scope of delivery	3
		Sensitivity	10
F		Silver / silver chloride anode	6
Filling electrolyte	14	Slope adjustment	10
Filling with electrolyte	11	Soiling of the membrane	11
Flow	4	Spare cartridges	14
Flow assembly OCA 250	4, 8	Start-up and calibration	9-10
Flow rate	7	Sterilised	4
Free chlorine	7	Storage	11
		Symbols	2
G		T	
General information	2-3	Technical data	14
Gold cathode	6	Temperature	4, 7
		Temperature sensor	6
I		Troubleshooting	12-13
Index	15	U	
Influences on the measuring signal	7	Unpacking	3
Installation in flow assemblies	8		
Intended use	2	W	
		Warranty	2
J		Z	
Junction box VBC	14	Zero adjustment	10
M			
Measuring and control system	4		
Measuring cable	14		
Measuring cell construction	6		
Measuring chamber	6		
Measuring range	4, 14		
Measuring system	5		
Membrane	6		
Membrane replacement	11		
Minimum flow rate	4		
N			
NTC temperature sensor	6		

Distributed by:



51503885