

Retractable Assembly for pH/Redox Measurement *OPA 472*

Compact Retractable Assembly for Installation of pH/Redox Electrodes in Tanks or Pipelines



Application

- Chemical industry
- Effluent treatment
- Plant design
- Tanks and process vats
- Pipelines or pipes

This compact retractable assembly permits replacement of the electrode while the tank is full or under process conditions with pressures of up to 6 bar. In connection with the complete system OPC 300 you can automatically clean and calibrate the electrodes. The material in contact with the medium is PP / PEEK / PVDF.

Your Benefits

- Compact design
- Electrode can be cleaned and calibrated without interrupting the process; electrode life is extended
- Reliable separation from process by stop bolt and O-ring seals
- Simple removal and installation of electrode during ongoing process
- Adaptation to process requirements by great variety of materials and designs available
- Can be automated with a pneumatic or electric control system

Function and System design

Function

The retractable assembly OPA 472 is intended for reliable in-process measurement of pH value and Redox. This assembly has been designed as a compact retractable assembly for the chemical industry, for plant design and for industrial effluent treatment. Without having to interrupt the process, the electrode can be

- separated from the process and moved to a rinse chamber manually or pneumatically;
- rinsed with water or cleaning solution;
- kept moist during interruptions in operation;
- removed;
- or calibrated.

The OPA 472 assembly is available in polypropylene (PP), polyether ether ketone (PEEK) or polyvinylidene fluoride (PVDF) versions. Depending on the application, you can choose

- the short assembly version (for use with 120 mm gel electrodes or 225 mm liquid KCl electrodes, immersion depth up to 108 mm) or
- the long assembly version (for use with 225 mm gel electrodes or 425 mm liquid KCl electrodes, immersion depth up to 215 mm).

The most commonly used process connections are available (see section Process connections).

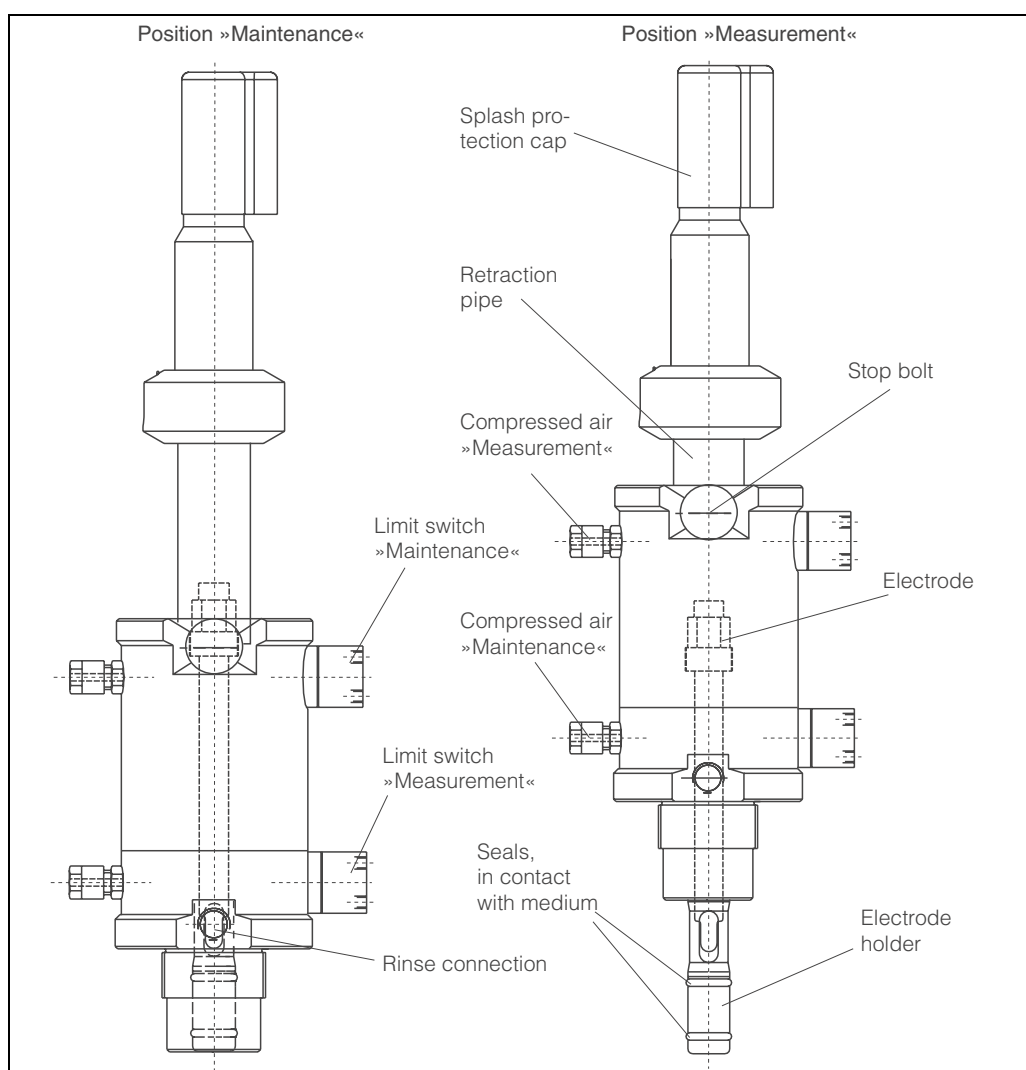

C07-OPA472xx-16-07-00-en-003.eps

Complete measuring system

Measuring system without control

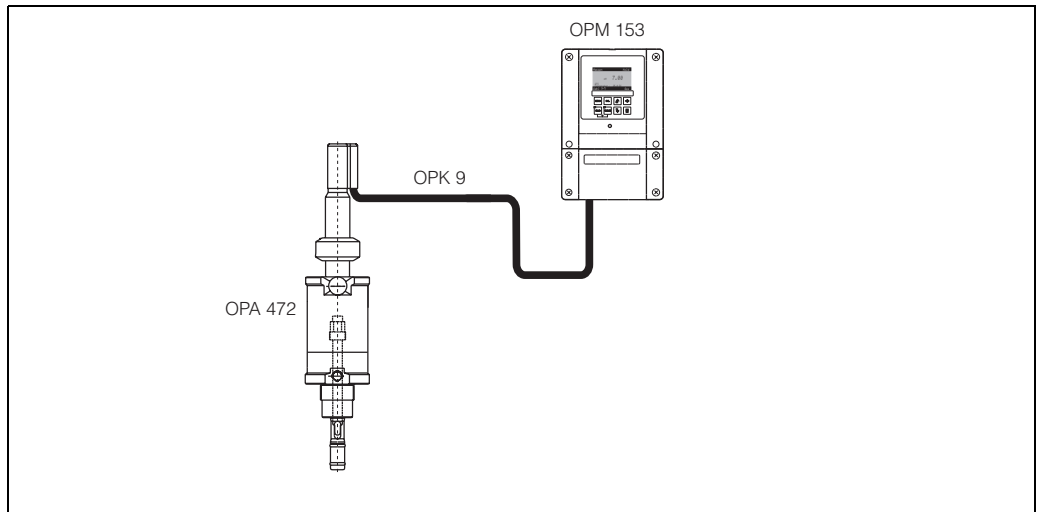

C07-OPA472xx-14-07-00-en-001.eps

Measuring system with pneumatic control

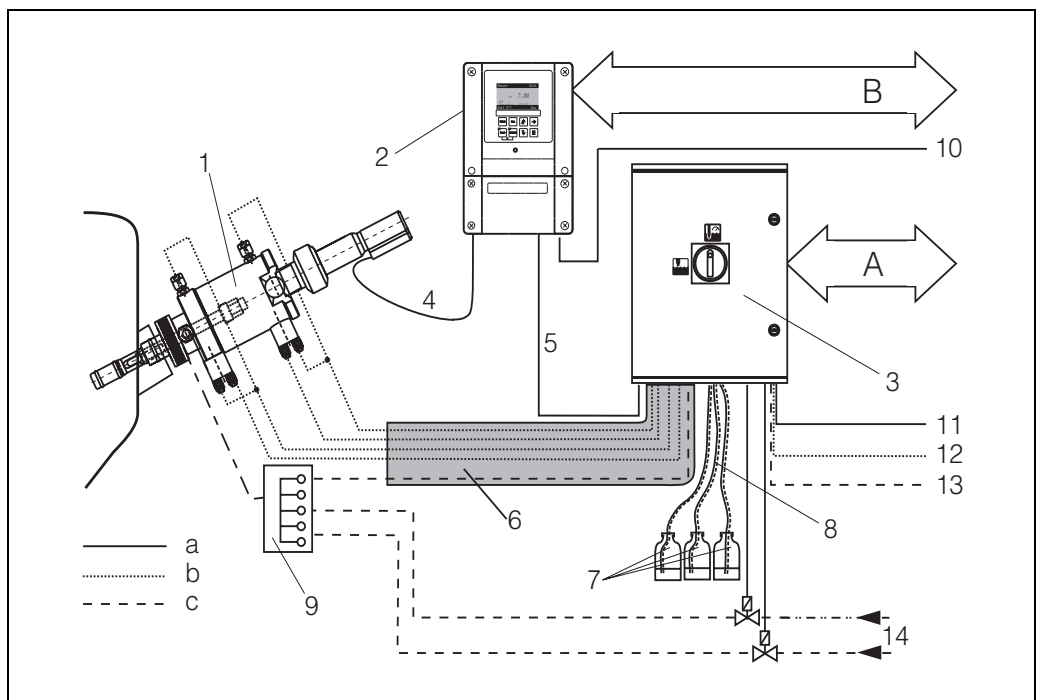

C07-OPA472xx-04-07-03-xx-001.eps

In connection with the complete system OPC 300 you can automate the pH measurement / cleaning / calibration.

- 1 Assembly OPA 472
- 2 Transmitter OPM 153
- 3 Control unit OPC 300
- 4 pH measuring cable
- 5 Power supply/control cable
- 6 Multihose
- 7 Canister for cleaning agent, buffer solutions
- 8 Hoses OPG 300 for canisters
- 9 Rinsing block (optional)
- 10 Power supply for OPM 153
- 11 Power supply for OPC 300
- 12 Pressurised air
- 13 Water
- 14 Superheated steam / water / other cleaning agents (optional)

Auxiliary energy / connections

Pneumatic connections for automatic assembly actuation

(if equipped accordingly)

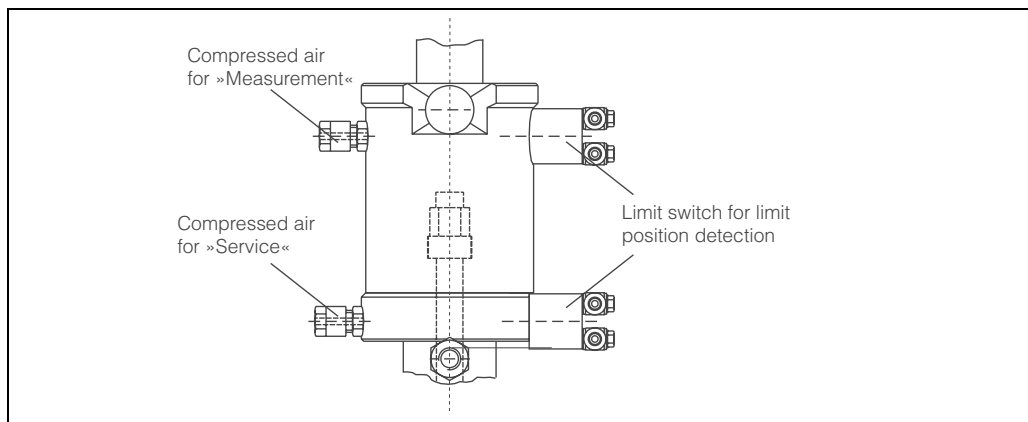

C07-OPA47xxx-04-07-00-en-001.eps

The OPA 472 assembly is operated with an air pressure of 4 to 8 bar. The air must be filtered (40 µm) and free from water and oil. There is no continuous pressure demand. The air lines must have a minimum nominal diameter of 4 mm.



Note!

If pressure increases to above 8 bar are likely (including short peak pressures), a pressure reducer *must* be installed. A pressure reducer is recommend for lower pressures as well for a softer starting of the assembly.

Connections for limit position detection

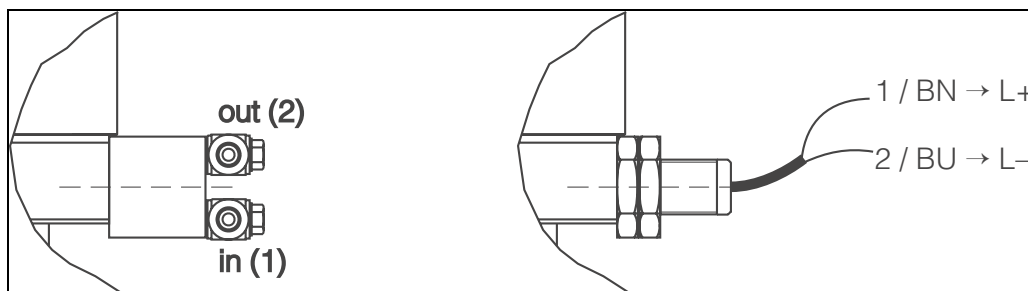

C07-OPA471xx-04-07-08-xx-001.cdr

left: pneumatic limit switch (1: compressed air inlet, 2: compressed air outlet)

right: inductive limit switch (NAMUR)

The lower limit switches are always used for the "Measurement" function, the upper switches for the "Maintenance" function.

Installation

The OPA 472 assembly is suitable for mounting on tanks or pipelines. Appropriate sockets are to be provided.

Orientation

A	Glass electrode:	Installation angle of at least 15° from the horizontal and the vertical
B	ISFET pH sensor:	No restrictions, 0 ... 180° recommended

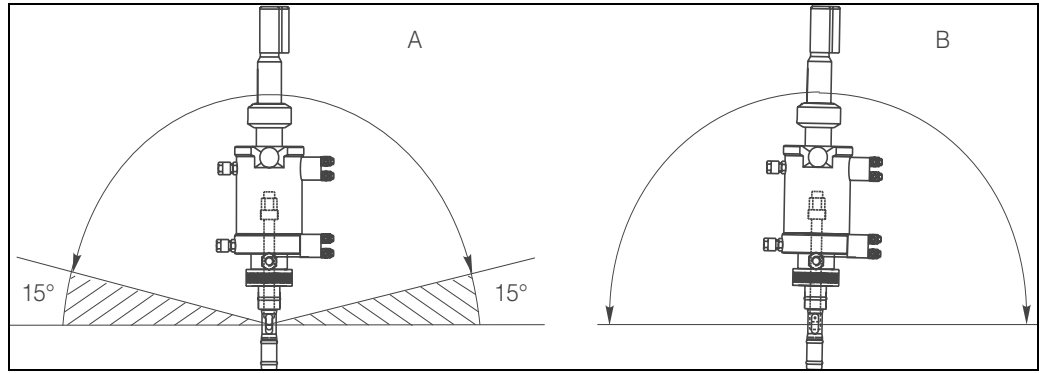

Valid orientation depending on the sensor used



Note!

- Pipe installation of the assembly requires a nominal diameter of at least DN 80.
- A flow chamber is to be used for smaller pipe diameters. The flow chamber is available as an accessory (DN 25, PVDF or DN 50, PP; order no. see section Accessories).

Environment

Ambient temperature range

The maximum permissible temperature for the limit switches (NAMUR type) is 90 °C. The ambient temperature must not drop below 0 °C.

Process

Process temperature range 0 ... 80 °C version in PVDF, PEEK
0 ... 60 °C version in PP

Process pressure range 0 ... max. 4 bar overpressure for manual actuation
0 ... 6 bar overpressure for pneumatic actuation and PA housing

Pressure temperature diagram

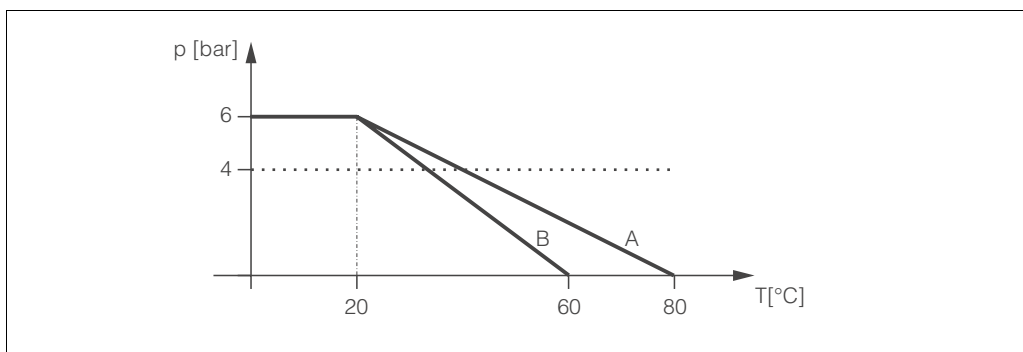

C07-OPA472xx-05-07-00-xx-001.eps

Pressure temperature diagram depending on the assembly material (overpressure)

A housing PA, material in contact with the medium PVDF, PEEK
B housing PA, material in contact with the medium PP

Medium velocity

Maximum permissible values for the medium velocity accrue in dependance on the medium temperature.

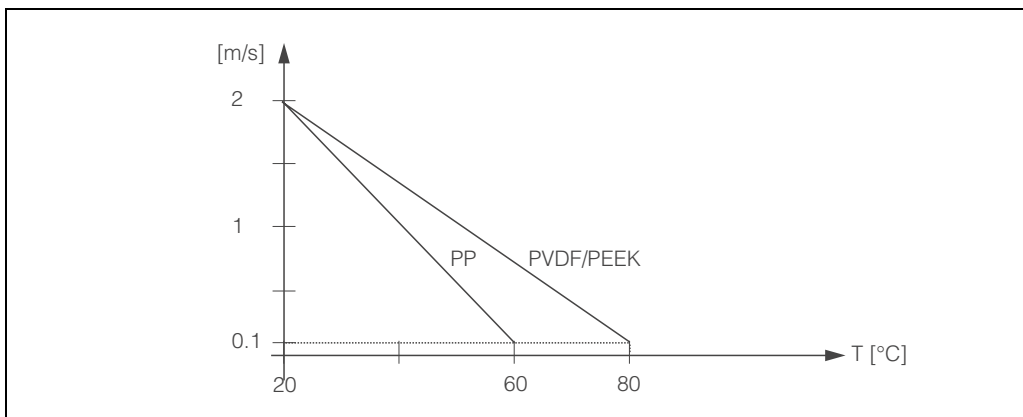

C07-OPA472xx-05-07-00-xx-002.eps

Medium velocity in m/s depending on the medium temperature in °C

Mechanical construction

Design, dimensions

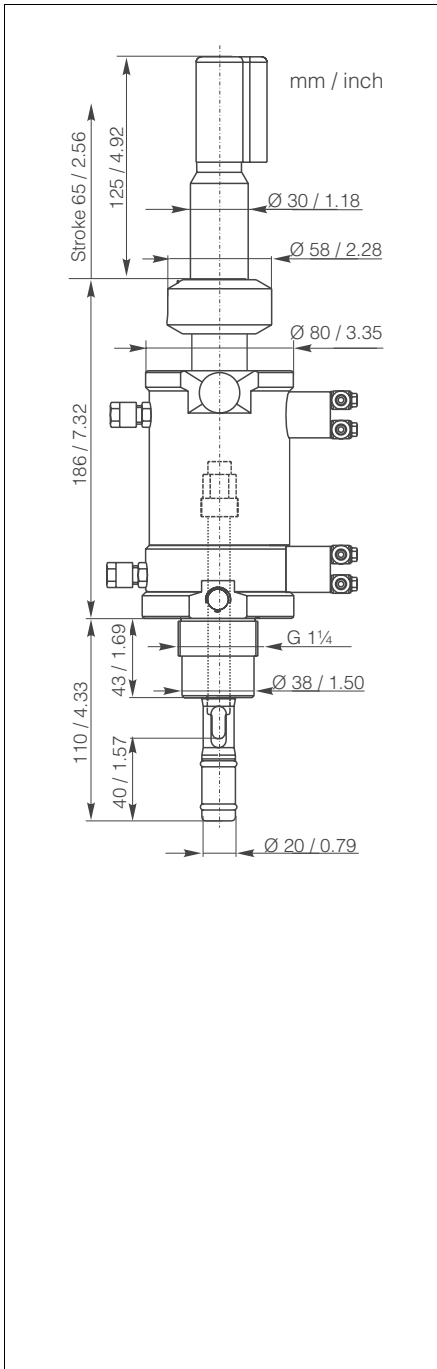

C07-OPA472xx-06-07-07-de-003.eps

OPA 472 in short version (for electrode length of 120 mm, gel electrodes OPS 11)

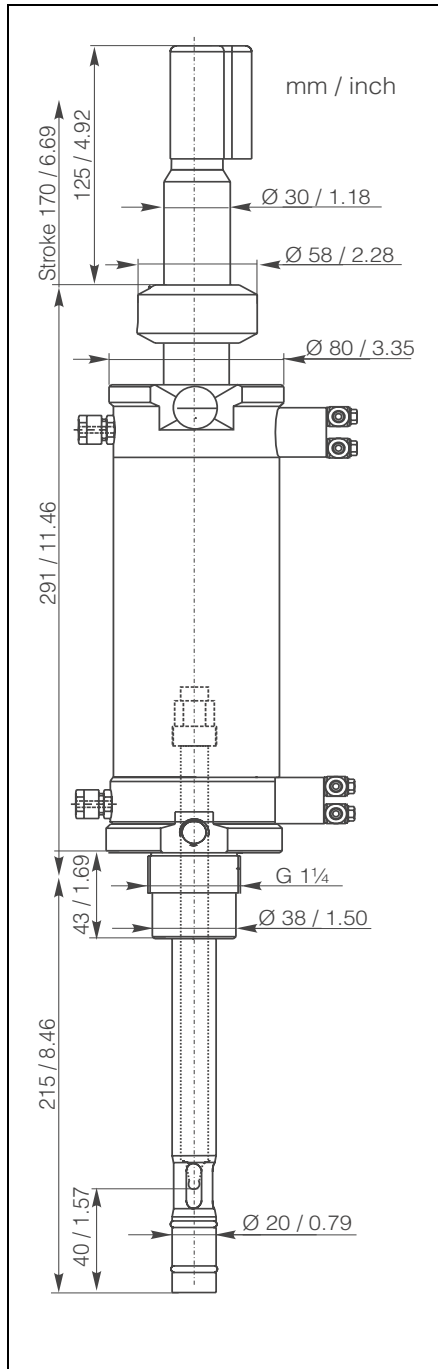

C07-OPA472xx-06-07-07-de-002.eps

OPA 472 in long version (for electrode length of 225 mm, gel electrodes OPS 11)

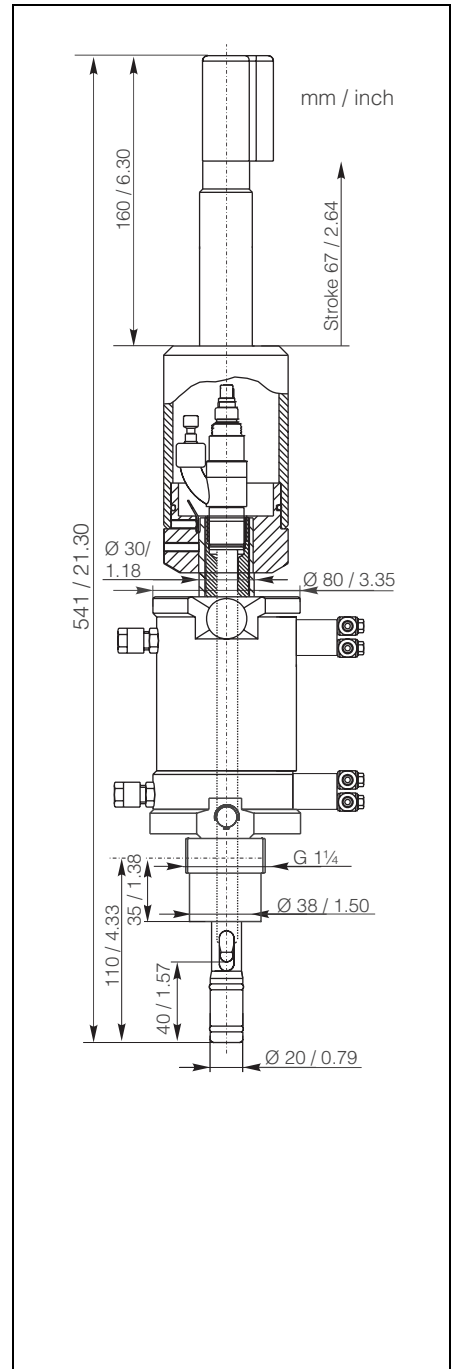

C07-OPA472xx-06-07-07-de-001.eps

OPA 472 in short version with 225 mm liquid KCl electrode OPS 41 (with hose connection for refilling with KCl)

Weight

Short version approx. 1.5 kg
Long version approx. 3 kg

Materials in contact with medium

Electrode holder: PP, PEEK, PVDF
 Seals: FPM (VITON®), KALREZ®

Materials not in contact with medium

Housing: Polyamide (PA)
 Limit switches (NAMUR type): fore-part PBT, cable PVC

Process connection

G 1¼ external thread, DN 50 flange, 2" ANSI flange, NPT 1" external thread, dairy fitting (DIN 11851)

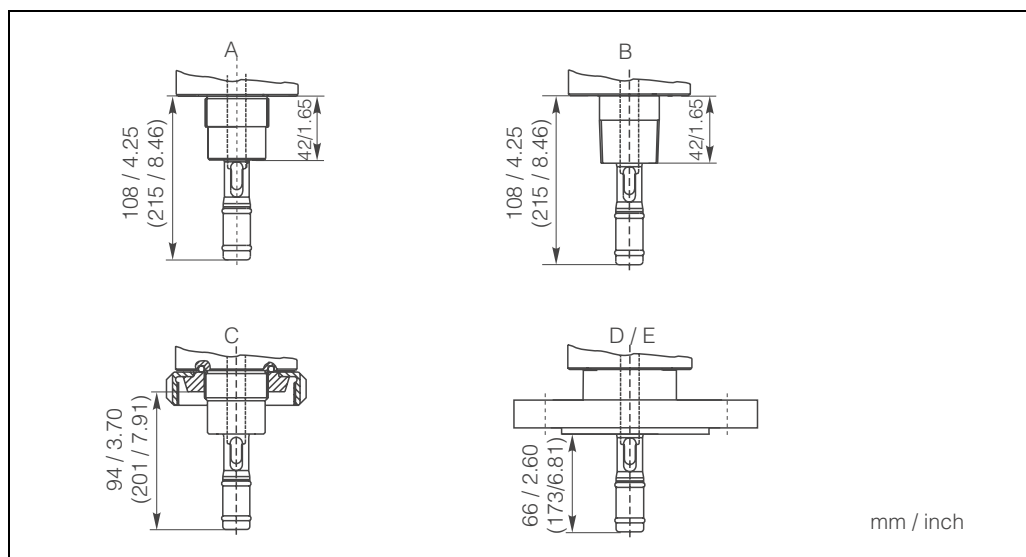

The immersion depth in mm is specified for each connection type (values in brackets are for long assembly version)

Rinse connection nozzles

2 x G ¼ (inside),
 2 x NPT ¼" (inside)

Pneumatic requirements

Pressure 4 ... 8 bar overpressure.
 Filtered air (40 µm), water-free, oil-free.
 The air hoses must have a minimum nominal diameter of 4 mm. For pressures above 6 bar pressure reducer are recommended to reduce the drive's stroke.

Limit switches

Pneumatic 3/2-way valve
 Inductive limit switches (NAMUR type)

Electrode placement

Short version:	gel electrodes	120 mm
	KCl electrode with KCl refilling:	225 mm
Long version	gel electrodes:	225 mm
	KCl electrode with KCl refilling:	425 mm

Certificates and approvals

Electric limit switches

The inductive limit switches meet the requirements of the DIN EN 60 947-5-6 (NAMUR).

Ordering information

Product structure for OPA 472

Compact retractable process assembly for pH / redox electrodes. For manual or pneumatic operation.

Drive type and limit switches										
A	Manual (cannot be converted to pneumatic)									
B	Pneumatic without limit switches (suitable for retrofitting)									
C	Pneumatic with 2 pneumatic limit switches									
D	Pneumatic with 2 electric limit switches (max. 90 °C)									
E	Pneumatic with 2 electric Ex limit switches (max. 90 °C)									
Assembly version										
1	Standard version									
Electrode holder										
A	For gel electrodes / ISFET sensor OPS 401 with Pg 13.5									
B	For liquid KCl electrodes with Pg 13.5 hose connection head									
Immersion depth										
1	Short version: up to 108 mm (depending on process connection) (possible electrode lengths: A = 120 mm, B = 225 mm)									
2	Long version: up to 215 mm (depending on process connection) (possible electrode length: A = 225 mm, B = 425 mm)									
9	Special version acc. to customer									
Assembly material (in contact with medium)										
A	PP (only with assembly version 1)									
B	PEEK									
C	PVDF									
D	PVDF with PEEK electrode holder									
Seal material (in contact with medium)										
2	FPM (Viton®)									
3	KALREZ®									
Process connection										
A	G 1¼ external thread									
B	NPT 1" external thread									
C	Dairy pipe NW 50 (acc to. DIN 11 851)									
D	DN 50 flange									
E	2" ANSI flange									
Optional equipment										
1	Without rinse connection (retrofitting not possible)									
3	With rinse fitting 2 x G ¼ internal thread									
4	With rinse fitting 2 x NPT ¼" internal thread									
OPA 472-										complete order code

Accessories

Welding socket

G1¼, internal thread, PP; order no.: 51502809
 G1¼, internal thread, PVDF; order no.: 51502810
 Dairy fitting DN 50, PP; order no.: 51502811 (with FPM / VITON® seal)
 Dairy fitting DN 50, PVDF; order no.: 51502812 (with FPM / VITON® seal)

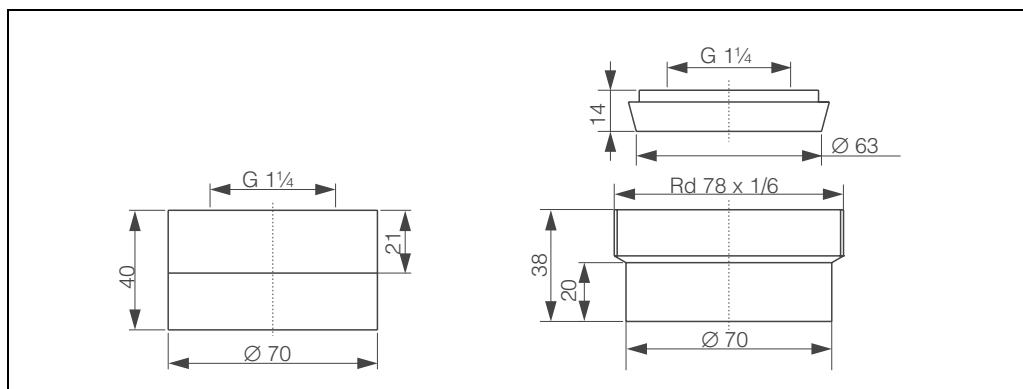

C07-OPA472xx-00-07-00-xx-003.eps

Welding socket straight or inclined

Flow chamber

DN 50, G 1¼ Innengewinde, PP; Bestell-Nr.: 51502815
 DN 25, Rd 78 Außengewinde, PVDF, Bestell-Nr.: 51502816

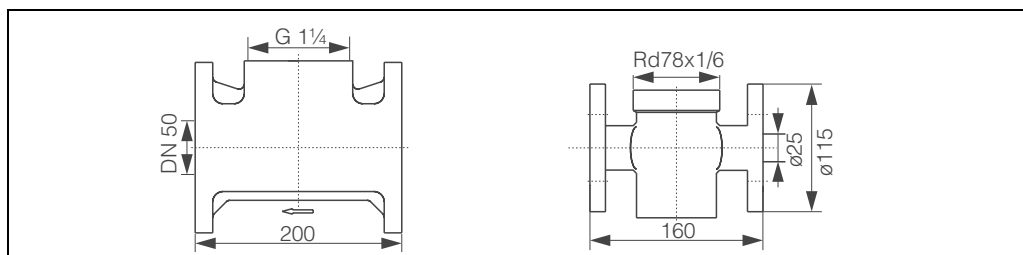

C07-OPA472xx-00-07-00-xx-001.eps

left flow chamber DN 50, PP
 right flow chamber DN 25, PVDF

Further flow chambers e.g. with / without sight glass, lined with PFA, in sizes DN 24, DN 50, DN 80, are available on request.

Rinse connection adapter

With the OPR 40, several media can be conveyed into a retractable assembly's rinse chamber.

Set of seals for contact with medium

VITON®; order no.: 51502813
 KALREZ®; order no.: 51502814 (not for flange connection)
 KALREZ® for flange connection; order no.: 51503472

pH/Redox combination electrodes, length 120 / 225 mm

Gel electrode OPS 11/12
 ISFET sensor OPS 401 (PEEK shaft; only 120 mm)

pH/Redox combination electrodes, length 225 / 425 mm

KCl liquid electrode OPS 41/42 (with ESS head)

Oxygen sensor, 120 mm

OOS 21

Hose nozzles for rinse connections G ¼, DN 12, PVDF (2 pcs.); order no.: 50090491

Retrofit Kit limit switches pneumatic limit switches (2 pcs.); order no.: 51502874
electric limit switches (ex or non-ex) (2 pcs.); order no.: 51502873

Protection cap On request
