

# Solids Content Sensor *OUS 41 / OUS 41-W*

**Process and immersion sensor for  
service water and solids content measurement  
based on multi-channel technology,  
also applying the 90° scattered light method**



## **Areas of application**

Optical solids content measurement is indispensable as a regulating variable for operation in following areas:

- Sewage treatment plants
  - Primary sludge
  - Activated sludge
  - Returned sludge
  - Putrefied sludge
  - Outlet
- Paper
  - Monitoring of sieve water
  - Water processing
- Concrete
  - Measurement of soiling
- Production
- Water processing
- Water monitoring

## **Benefits at a glance**

- Measuring range from 0.01 FNU to 100 g/l
  - from completely clear to completely black
- Scratch-proof sapphire windows
- Compact shock-proof design
- For installations in pipes or basins
- Simple commissioning
- 3-point calibration and 1-point adjustment
- 7 calibration data records according to customer specifications can be stored
- Wiper cleaning integrated or retrofitted
- Inclined flat sensor surface uses medium flow to increase self-cleaning effect
- Permissible distance between sensor and transmitter up to 200 m

# Measuring system

A measuring system consists of:

- OUS 41 solids content sensor
- OUM 223 transmitter

Examples of complete measuring systems

*left:*  
OUS 41 in OUA 461 retractable assembly

*right:*  
OUS 41 in immersion assembly

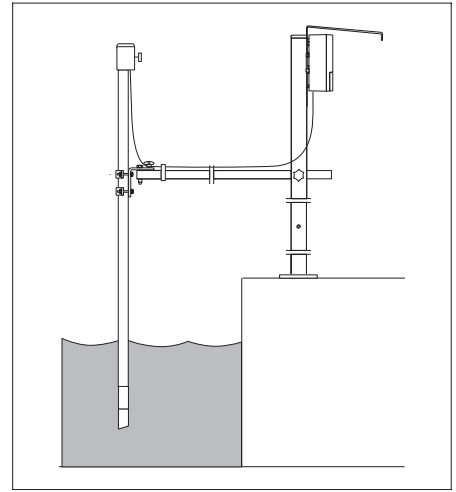
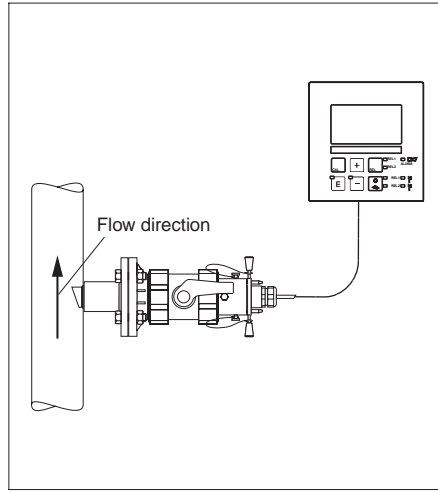

# Functional principle

The 90° scattered light method with a measuring frequency in the near-infrared range of light (880 nm) according to ISO 7027 / EN 27027 guarantees a measurement of the turbidity value under standardised, comparable conditions.

The excitation radiation of an infrared transmitter strikes the medium at a defined angle of beam. The different refractive indices of the entrance window and the measuring medium (water) are taken into account. Particles in the medium generate a scattered radiation which strikes the scattered light receiver at a defined angle. The measurement in the medium is constantly adjusted with the values of a reference receiver.

Digital filter functions with an excellent interference signal suppression and sensor self-monitoring ensure additional measurement reliability.

In addition to the turbidity signal, a temperature measurement signal is detected and transmitted.



- ① LED
- ② photodiode
- ③ photodiode
- ④ wiper (optional)

# Calibration

Every sensor in the “FNU field of application” is carefully factory-calibrated using standard procedures. Other customer- and substance-specific calibrations can also be stored. Depending on the different precise requirements in service or drinking water, special assemblies with the integrated calibration values are provided.

For service water measurements, standard specifications are usually sufficient. However, installing the sensor in a pipe or very close to a wall can cause backscatter resulting in a higher signal. To compensate for this, an installation adjustment must be performed.

# Notes on installation and application

Dependence of the measurement on the wall or floor distance

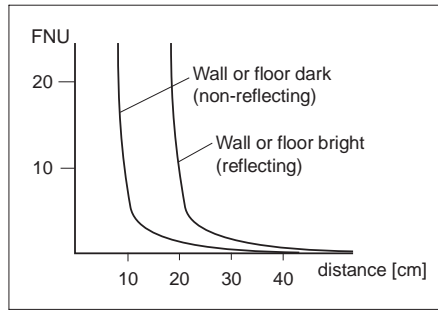

## Wall distance

The effective wall or floor distance can be optimised by aligning with the flat sensor side. The opposite figure shows the influence of this distance on the measurement with bright or dark shading of wall or floor. As a rule, the OUS 41 sensor should be immersed at least 4 cm into the medium to be measured.

Self-cleaning by flow against the inclined sensor surface

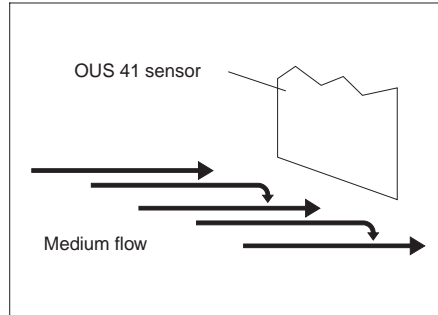

## Self-cleaning

Optimum self-cleaning and sufficient wall distance (e.g. in narrow channels) are achieved by turning the inclined sensor surface into the flow direction. Some time after initial operation, the sensor should be checked for dirt. To clean it, wipe with a soft cloth. The most favourable sensor position should be maintained. Should self-cleaning not be sufficient, then we recommend the wiper sensor OUS 41-W.

# Installation in immersion assemblies

Assembly holder OYH 101

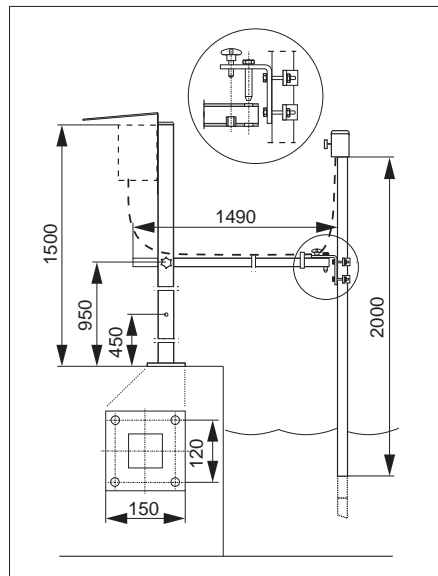

## Note

When installing OUS 41 in an immersion assembly, such as OYA 611 with a pendulum frame, please note that sufficient wall distance must be maintained during the measuring process. The assembly should be installed where a minimum wall distance of 15 cm is guaranteed even with varying medium levels or changing flow conditions. Installation in a suspension assembly with chain must therefore be avoided.

## Mounting

- Remove cover from holding tube.
- Pull connection cable through holding tube without twisting it; screw in sensor and turn to the stop.

### Note:

- First undo twists in cable by reverse twisting.
- Put on cover.
- Secure sensor cable to transverse pipe and connect it to the instrument, or if used, to the junction box.

OUS 41 sensor installed in OYA 611 assembly with pendulum frame

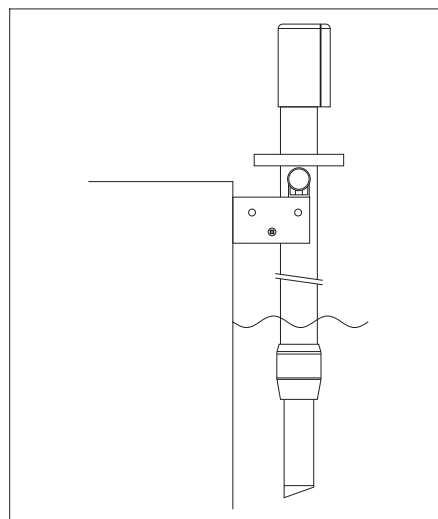

# Pipe installation

Orientation and positions of OUS 41 with OUA 120-A/B adapter or OUA 461 retractable assembly

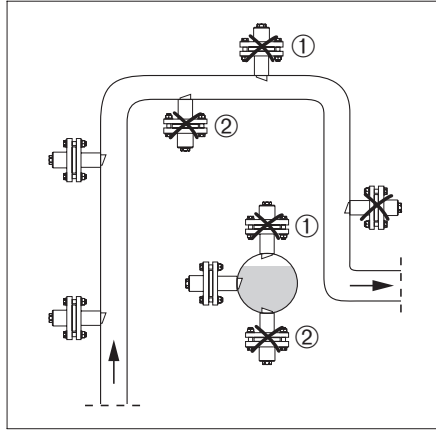

## Notes

- The pipe diameter must be at least DN 100 when shiny materials (e.g. stainless steel) are used.
- Install the sensor in places with uniform flow conditions. Do not install it in places where air may collect, where foam bubbles are likely to form (①) or where suspended solids may settle (②).
- Install the sensor surface against the medium flow.

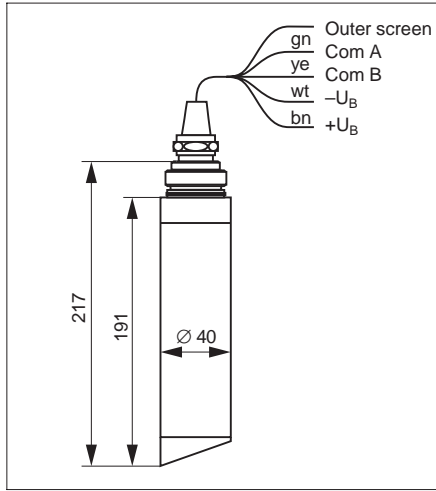

OUS 41 sensor

## Mounting

- Lead connection cable through sleeve and hexagon coupling without twisting it.
- Insert sensor body into the sleeve so that the O-ring adjoins under the G 1" screw thread in the sleeve. Note marking pin and marking hole on the sleeve.
- Install OUS 41 into the adapter in such a way that the acute-angled edge of the sensor lies opposite to the marking hole and points away from it. The marking hole renders the sensor orientation clearly identifiable.

*left:*  
OUA 120-B adapter with welding neck DN 50 / ANSI 2" (accessory) and lap joint flange DN 50 / ANSI 2" (to be provided by customer)

*right:*  
Process connection adapter for pipe diameter greater than 80 mm

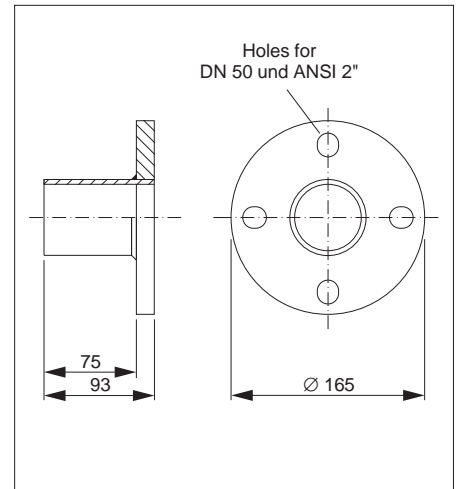
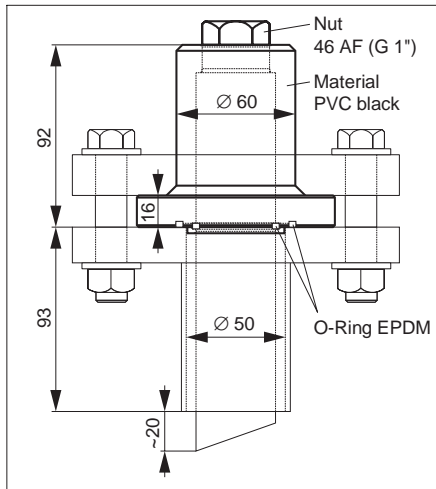

## Welding neck DN 50 / ANSI 2"

Material	Order no.
Stainless steel 1.4571 (SS 316Ti)	50080249
Polyvinyl chloride PVC	50080250
Polypropylene PP	50080251

## Pipe installation (continued)

- Dimensions of  
Probit OUA 461  
assembly
- 1 Process connection  
DIN Flange DN 50  
or ANSI 2"
  - 2 Process connection  
adapter  
(accessory, see p. 4)

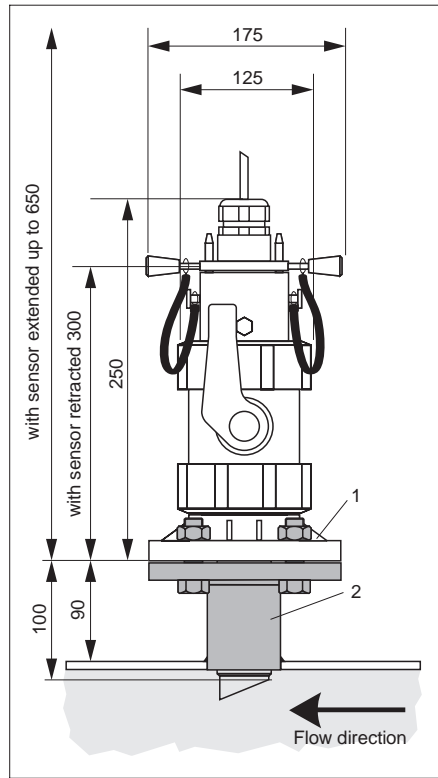

For a description of the assembly, refer to Technical Information TI 134C/07/en, order no. 50073613.

## Installation in flow assemblies

### Notes on installation

- The medium should, if possible, flow into the assembly from below. If the flow assembly must be installed in a horizontal instead of a vertical position, then install the sensor in the 3 o'clock or 9 o'clock position. This helps avoid air pockets.
- Installing the sensor parallel to the medium flow is necessary:
  - for turbidities < 5 FNU to minimise wall reflection effects.
  - Also carry out installation adjustment!
  - in conjunction with the spray head OUR 3.
- Installing the sensor against the medium flow is used to increase self-cleaning effects:
  - in heavily soiled media with turbidities > 15 FNU, where wall reflections can in any case be neglected due to the high absorption rate.

### Sensor orientation parallel to the medium flow

The sensor is inserted into the union nut. Loosely tighten the hexagon coupling on the G 1" thread of the sensor. When the sensor is inserted with the sleeve on, the fitting hole on the upper edge of the assembly accommodates the locking pin. Position the sensor by turning it in such a way that the sharp edge formed by inclined sensor surface and sensor cylinder lies opposite the marking pin and points away from it. The spray-head connection in the T-section of the OUA 250 is now located over the sensor surface.

### Sensor orientation against the medium flow

Position the sensor by turning it until the sharp edge formed by inclined sensor surface and sensor cylinder lies turned by 90° opposite the marking pin and points in the flow direction of the medium. Hand-tighten the hexagon nut.

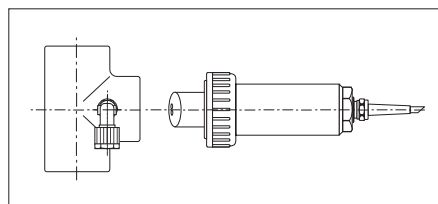

Installed parallel to  
the medium flow

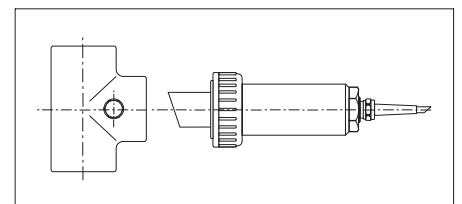

Installed against  
the medium flow

## Installation in flow assemblies (continued)

### OUA 250-A, OUA 250-B

- Lead connection cable through union nut, sleeve and hexagon coupling without twisting it.
- Insert sensor body into the sleeve so that the O-ring adjoins under the G 1" screw thread in the sleeve. Note locking pin and marking hole on the sleeve.

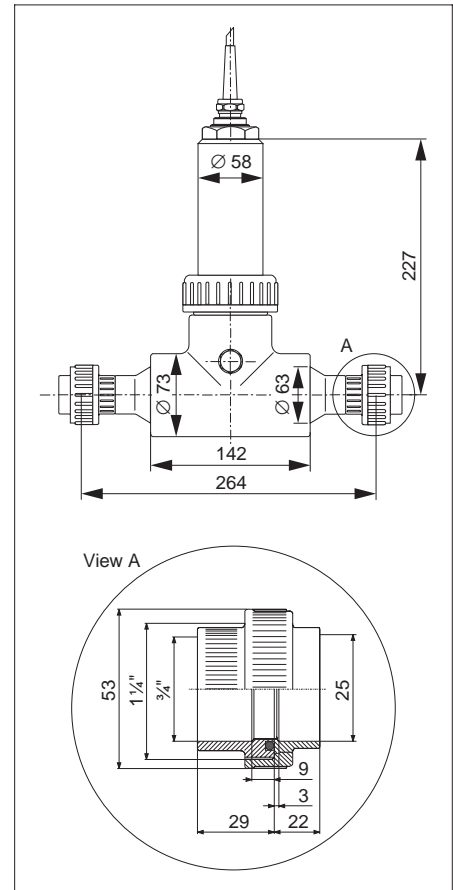

Dimensions  
OUA 250-A/B

## Turbidity sensor with wiper cleaning

The OUS 31/41-W sensors are both equipped with a screen wiper. The cleaning times and intervals are entered into the OUM 223 transmitter. For optimum cleaning, wiper timing is adjustable.

### Checking the rest position

- Pull the sensor from the assembly.
- Moisten the sensor surface.
- Set type of cleaning and cleaning times on the transmitter and start the wiping cycle.
- Check the wiper movement (cycle) on the sensor. The wiper must reach the rest position (see figure).



#### Caution:

Do not move the wiper arm by hand!



#### Note:

If the wiper comes to rest over the measuring windows, then measuring errors will result.

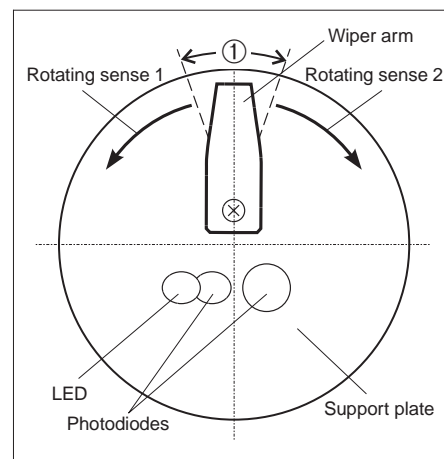

① Rest position of the wiper arm  
Tolerance range:  $\pm 20^\circ$

## Maintenance and cleaning

Deposits on the sensor optics may result in inaccurate measurement. Therefore the sensor must be cleaned at regular intervals. The intervals are specific to each installation and must be determined during operation. Clean the optics with the following agents depending on the type of soiling:

- Clean the sensor mechanically using a soft brush. Then rinse thoroughly with water.



#### Warning:

- Do not touch the optics with sharp-edged objects.
- Do not scratch the optics.

Type of soiling	Cleaning agent
Limestone deposits	Short treatment with commercial delimiting agent
Oily and greasy soiling	Cleaning agents based on water-soluble surfactants (e.g. household dish detergents)
Other types of soiling	With water and brush

## Technical data

Measuring principle	nephelometric 90° NIR scattered light according to EN 27027
Measuring ranges	0.00 ... 9999 FNU, 0.00 ... 9999 ppm, 0.0 ... 300 g/l, 0.0 ... 200.0% (depending on the type of sample)
Wavelength	880 nm
Optical reference compensation	by reference photodiodes
Factory calibration	formazine standard and SiO <sub>2</sub>
Temperature / pressure	25 °C / 6 bar ... 50 °C / 1 bar
Connecting cable	4-core with terminal bushes
Max. cable length	200 m
Temperature sensor	NTC
Nominal operating range	-5 ... +50 °C
Storage temperature range	-20 ... +60 °C
Ingress protection	IP 68

### Materials

Sensor support plate, shaft, cable	PVC
Optical windows	sapphire
Flow assemblies	PVC

## How to order

Solids content sensor OUS 41	
<p><b>Sensor</b>            A Sensor in standard version            W Sensor with integrated wiper</p>	
<p><b>Cable length</b>            2 Connecting cable 7 m            4 Connecting cable 15 m            9 Connection cable according to customer specifications</p>	
<p>↓ ↓</p> <p>OUS 41- <input type="text"/> <input type="text"/></p>	<p><b>complete order code</b></p>