

# Operating Instructions

## OLM223/253

### Transmitter for Conductivity

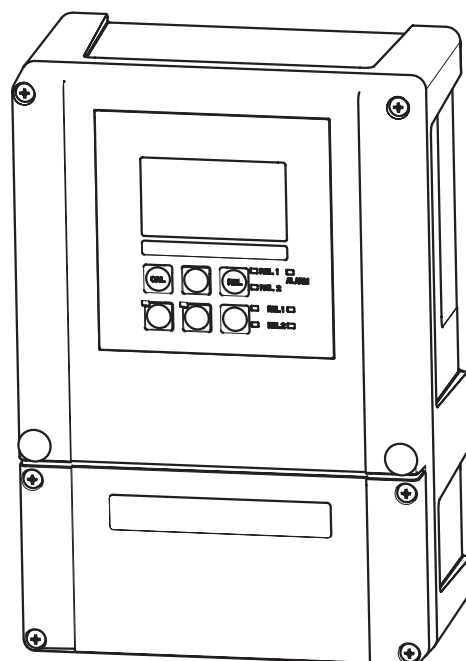
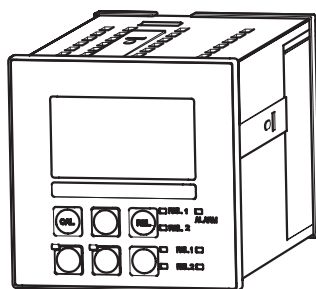

# Brief operating instructions

This explains how to use these Operating Instructions to commission your transmitter quickly and safely:

Page 4 ff. Page 5 ff.	<b>Safety instructions</b> General safety instructions Explanation of the warning symbols You can find special instructions at the appropriate position in the chapter in question. The positions are indicated with the icons Warning ⚠, Caution ⚡ and Note 📌
Page 9 ff. Page 11 ff.	<b>Installation</b> Here you can find information on installation conditions and the dimensions of the transmitter. You can find information on how to install the transmitter on these pages.
Page 16 ff.	<b>Wiring</b> Here you can find out how to connect sensors to the transmitter.
Page 21 ff. Page 26 ff. Page 33 ff. Page 67 ff.	<b>Operation</b> The display and operating elements are described here. The operating concept is explained here. The system configuration is explained here. You can find information on how to calibrate the sensor on these pages.
Page 70 ff. Page 75 ff. Page 79 ff. Page 87 ff.	<b>Maintenance</b> Here you can find information on the maintenance of the entire measuring point. The accessories which can be delivered for the transmitter are listed on the pages indicated. Here you can find information on trouble-shooting. Here you can find an overview of the spare parts which can be delivered as well as an overview of the system.
Page 9 ff. Page 94 ff.	<b>Technical data</b> Dimensions Ambient and process conditions, weight, materials etc.
Page 98 ff.	<b>Appendix</b> Here you can find the operating matrix

# Table of contents

<b>1</b>	<b>Safety instructions</b> . . . . .	<b>4</b>	<b>8</b>	<b>Accessories</b> . . . . .	<b>75</b>
1.1	Designated use . . . . .	4	8.1	Sensors . . . . .	75
1.2	Installation, commissioning and operation . . . . .	4	8.2	Connection accessories . . . . .	75
1.3	Operational safety . . . . .	4	8.3	Mounting accessories . . . . .	76
1.4	Return . . . . .	5	8.4	Assemblies . . . . .	77
1.5	Notes on safety icons and symbols . . . . .	5	8.5	Software and hardware add-ons . . . . .	78
<b>2</b>	<b>Identification</b> . . . . .	<b>6</b>	8.6	Calibration solutions . . . . .	78
2.1	Device designation . . . . .	6	8.7	Optoscope . . . . .	78
2.2	Scope of delivery . . . . .	7	<b>9</b>	<b>Trouble-shooting</b> . . . . .	<b>79</b>
2.3	Certificates and approvals . . . . .	7	9.1	Trouble-shooting instructions . . . . .	79
<b>3</b>	<b>Installation</b> . . . . .	<b>8</b>	9.2	System error messages . . . . .	79
3.1	Quick installation guide . . . . .	8	9.3	Process specific errors . . . . .	82
3.2	Incoming acceptance, transport, storage . . . . .	9	9.4	Instrument specific errors . . . . .	85
3.3	Installation conditions . . . . .	9	9.5	Spare parts . . . . .	87
3.4	Installation instructions . . . . .	11	9.6	Return . . . . .	93
3.5	Post-installation check . . . . .	14	9.7	Disposal . . . . .	93
<b>4</b>	<b>Wiring</b> . . . . .	<b>15</b>	<b>10</b>	<b>Technical data</b> . . . . .	<b>94</b>
4.1	Electrical connection . . . . .	16	10.1	Input . . . . .	94
4.2	Post-connection check . . . . .	20	10.2	Output . . . . .	94
<b>5</b>	<b>Operation</b> . . . . .	<b>21</b>	10.3	Power supply . . . . .	96
5.1	Quick operation guide . . . . .	21	10.4	Performance characteristics . . . . .	96
5.2	Display and operating elements . . . . .	21	10.5	Environment . . . . .	96
5.3	Local Operation . . . . .	25	10.6	Mechanical construction . . . . .	97
<b>6</b>	<b>Commissioning</b> . . . . .	<b>28</b>	<b>11</b>	<b>Appendix</b> . . . . .	<b>98</b>
6.1	Function check . . . . .	28		<b>Index</b> . . . . .	<b>102</b>
6.2	Switching on . . . . .	28			
6.3	Quick start-up . . . . .	30			
6.4	System configuration . . . . .	33			
6.5	Communication . . . . .	66			
6.6	Calibration . . . . .	67			
<b>7</b>	<b>Maintenance</b> . . . . .	<b>70</b>			
7.1	Maintenance of the entire measuring point . . . . .	70			
7.2	"Optoscope" service tool . . . . .	74			

# 1 Safety instructions

## 1.1 Designated use

OLM223/253 is a transmitter for determining the conductivity and the resistivity of a liquid medium.

The transmitter is particularly suited for use in the following areas:

- Ultrapure water
- Water treatment
- Cooling water desalination
- Condensate treatment
- Municipal sewage treatment plants
- Chemical industry
- Food industry
- Pharmaceutical industry

Any other use than the one described here compromises the safety of persons and the entire measuring system and is, therefore, not permitted.

The manufacturer is not liable for damage caused by improper or non-designated use.

## 1.2 Installation, commissioning and operation

Please note the following items:

- Installation, electrical connection, commissioning, operation and maintenance of the measuring system must only be carried out by trained technical personnel. The technical personnel must be authorised for the specified activities by the system operator.
- Technical personnel must have read and understood these Operating Instructions and must adhere to them.
- Before commissioning the entire measuring point, check all the connections for correctness. Ensure that electrical cables and hose connections are not damaged.
- Do not operate damaged products and secure them against unintentional commissioning. Mark the damaged product as being defective.
- Measuring point faults may only be rectified by authorised and specially trained personnel.
- If faults can not be rectified, the products must be taken out of service and secured against unintentional commissioning.
- Repairs not described in these Operating Instructions may only be carried out at the manufacturer's or by the service organisation.

## 1.3 Operational safety

The transmitter has been designed and tested according to the state of the art and left the factory in perfect functioning order.

Relevant regulations and European standards have been met.

As the user, you are responsible for complying with the following safety conditions:

- Installation instructions
- Local prevailing standards and regulations.

Ex systems have an additional Ex documentation which is part of the Operating Instructions (see also chapter "Scope of delivery").

### **EMC**

This instrument has been tested for electromagnetic compatibility in industrial use according to applicable European standards.

Protection against interference as specified above is valid only for an instrument connected according to the instructions in these Operating Instructions.

## 1.4 Return

If the device requires repair, please send it *cleaned* to the sales centre responsible. Please use the original packaging, if possible.

## 1.5 Notes on safety icons and symbols

### Safety icons



**Warning!**

This symbol alerts you to hazards. They can cause serious damage to the instrument or to persons if ignored.



**Caution!**

This symbol alerts you to possible faults which could arise from incorrect operation. They could cause damage to the instrument if ignored.



**Note!**

This symbol indicates important items of information.

### Electrical symbols



**Direct Current (DC)**

A terminal at which DC is applied or through which DC flows.



**Alternating Current (AC)**

A terminal at which (sine-form) AC is applied or through which AC flows.



**Ground connecting**

A terminal, which, from the user's point of view, is already grounded using a grounding system.



**Protective earth terminal**

A terminal which must be grounded before other connections may be set up.



**Alarm relay**



**Input**



**Output**



**DC voltage source**



**Temperature sensor**

## 2 Identification

### 2.1 Device designation

#### 2.1.1 Product structure

Version	
CD	Conductivity/resistivity measurement (conductive two-electrode sensor)
CS	Conductivity/resistivity measurement (conductive two-electrode sensor) with additional functions (Plus package)
ID	Conductivity measurement (inductive sensor)
IS	Conductivity measurement (inductive sensor) with additional functions (Plus package)

Power supply; approval	
0	230 V AC
1	115 V AC
2	230 V AC; CSA Gen. Purp.
3	115 V AC; CSA Gen. Purp.
4	230 V AC; ATEX II 3G [EEx nAL] IIC
5	100 V AC
6	24 V AC/DC; ATEX II 3G [EEx nAL] IIC for OLM223, EEx nA[L] IIC T4 for OLM253
7	24 V AC/DC; CSA Gen. Purp.
8	24 V AC/DC

Output	
0	1 x 20 mA, conductivity/resistivity
1	2 x 20 mA, conductivity/resistivity and temperature/main measured value/actuating variable
3	PROFIBUS PA
4	PROFIBUS DP
5	1 x 20 mA, conductivity/resistivity HART®
6	2 x 20 mA, conductivity/resistivity HART® and temp./main measured value/actuating variable

Additional contacts; analogue input	
05	Not selected
10	2 x relay (limit/controller/timer)
15	4 x relay (limit/controller/Chemoclean)
16	4 x relay (limit/controller/timer)
20	2 x relay (limit/controller/timer); current input
25	4 x relay with cleaning (limit/controller/timer/Chemoclean); current input
26	4 x relay with timer (limit/controller/timer); current input

OLM253-					complete order code
OLM223-					

#### 2.1.2 Additional functions of the Plus Package

- Current output table to cover large areas with varying resolution, fields O33x
- Process Check System (PCS): live check of the sensor, function group P
- Ultrapure water monitoring for "Water for injection" (WFI) and "Purified water" (PW) acc. to United States Pharmacopeia (USP) and European Pharmacopoeia (EP) with pre-alarm (conductive, additional contacts necessary), fields R26x and R27x
- Polarisation detection (conductive), function group P
- Concentration measurement, function group K
- Temperature compensation via coefficient table, function group T
- Adaptive calibration with installation factor (inductive), fields C13x
- Automatic cleaning function start, field F8

## 2.2 Scope of delivery

The delivery of the field instrument includes:

- 1 transmitter OLM253
- 1 plug-in screw terminal
- 1 cable gland Pg 7
- 1 cable gland Pg 16 reduced
- 2 cable glands Pg 13.5
- 1 operating instructions BA193e00
- versions with HART communication:
  - 1 operating instructions Field Communication with HART, BA208e00
- versions with PROFIBUS communication:
  - 1 operating instructions Field Communication with PROFIBUS PA/DP, BA209e00
- versions with explosion protection for hazardous area zone II (ATEX II 3G):
  - Safety instructions for use in explosion-hazardous areas, XA194a300

The delivery of the panel mounted instrument includes:

- 1 transmitter OLM223
- 1 set of plug-in screw terminals
- 2 tensioning screws
- 1 operating instructions BA193e00
- versions with HART communication:
  - 1 operating instructions Field Communication with HART, BA208e00
- versions with PROFIBUS communication:
  - 1 operating instructions Field Communication with PROFIBUS PA/DP, BA209e00
- versions with explosion protection for hazardous area zone II (ATEX II 3G):
  - Safety instructions for use in explosion-hazardous areas, XA194a300

If you have any questions, please contact your supplier or your sales centre responsible.

## 2.3 Certificates and approvals

### Declaration of conformity

The product meets the legal requirements of the harmonised European standards.

The manufacturer confirms compliance with the standards by affixing the **CE** symbol.

### Explosion protection for Zone 2

Version	Approval
OLM253-..6...	ATEX II 3G EEx nA[L] IIC T4
OLM253-..4... OLM223-..4... OLM223-..6...	ATEX II 3G [EEx nAL] IIC

The safety instructions for explosion-hazardous areas, XA194a300, are part of the operating instructions.

### 3 Installation

#### 3.1 Quick installation guide



**Warning!**

If the measuring point or parts of the measuring point are in explosion-hazardous areas you have to follow the "Safety instructions for electrical apparatus certified for use in explosion-hazardous areas". These instructions (XA194a300) are part of the scope of delivery.

Proceed as follows to completely install the measuring point:

- Install the transmitter (see "Installation instructions" section).
- If the sensor is not yet installed in the measuring point, install it (see Technical Information of the sensor).
- Connect the sensor to the transmitter as illustrated in the "Electrical connection" section.
- Connect the transmitter as illustrated in the "Electrical connection" section.
- Commission the transmitter as explained in the "Commissioning" section.

#### 3.1.1 Measuring system

A complete measuring systems comprises:

- The transmitter OLM223 or OLM253
- A sensor with or without an integrated temperature sensor
- A measuring cable OYK71 (conductive), OPK9 for OLS16 or OLK5 (inductive)

Options: extension cable, junction box VBM

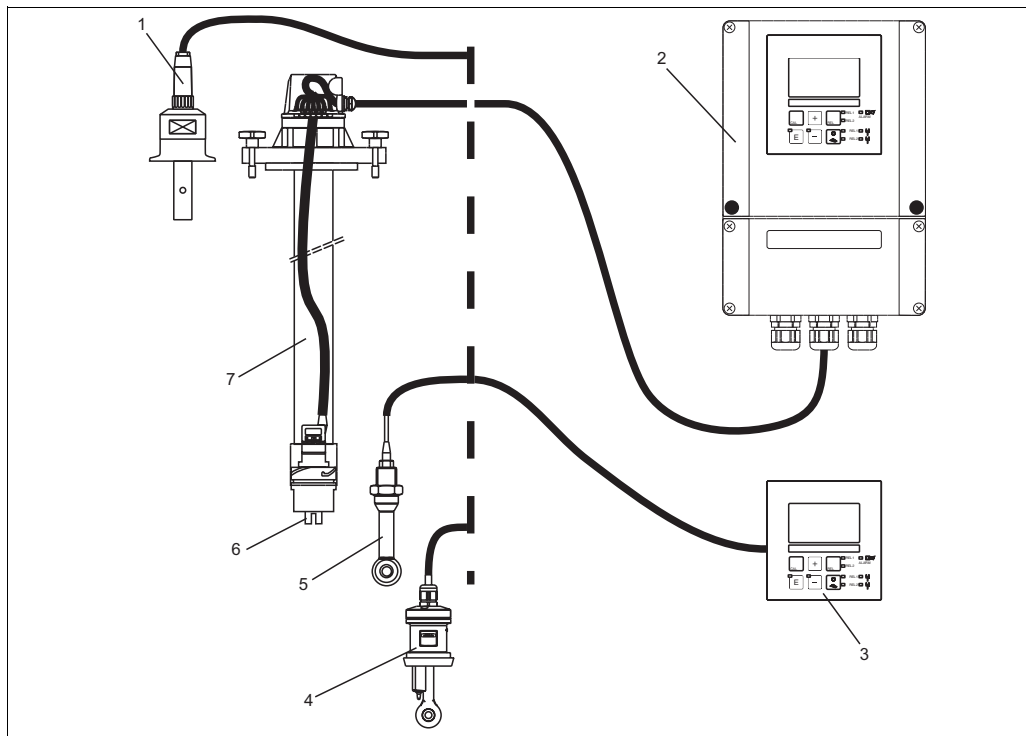

C07-OLM2x3xx-14-06-00-xx-001.eps

Fig. 1: Complete measuring system OLM223/253

- |                           |                             |
|---------------------------|-----------------------------|
| 1 Conductive sensor OLS15 | 5 Inductive sensor OLS50    |
| 2 Transmitter OLM253      | 6 Conductive sensor OLS21   |
| 3 Transmitter OLM223      | 7 Immersion assembly OLA111 |
| 4 Inductive sensor OLS52  |                             |

## 3.2 Incoming acceptance, transport, storage

- Make sure the packaging is undamaged!  
Inform the supplier about damage to the packaging.  
Keep the damaged packaging until the matter has been settled.
- Make sure the contents are undamaged!  
Inform the supplier about damage to the delivery contents.  
Keep the damaged products until the matter has been settled.
- Check that the scope of delivery is complete and agrees with your order and the shipping documents.
- The packaging material used to store or to transport the product must provide shock protection and humidity protection. The original packaging offers the best protection. Also, keep to the approved ambient conditions (see "Technical data").
- If you have any questions, please contact your supplier or your sales centre responsible.

## 3.3 Installation conditions

### 3.3.1 Field instrument

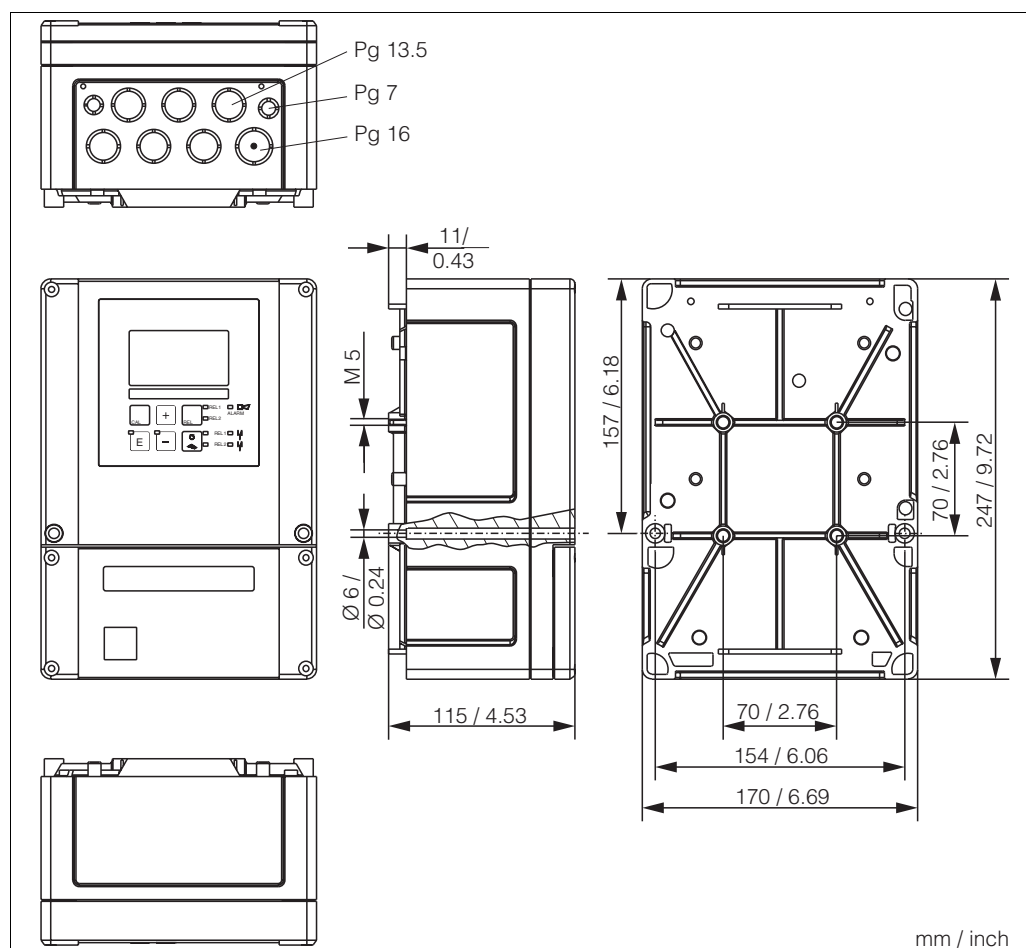

C07-OxM253xx-06-06-00-en-001.EPS

Fig. 2: Field instrument



#### Note!

There is a hole in the punching for the cable entry (connection of supply voltage). It serves as a pressure balance during air freight dispatching. Make sure no moisture penetrates the inside of the housing before the cable installation. The housing is completely air-tight after the cable installation.

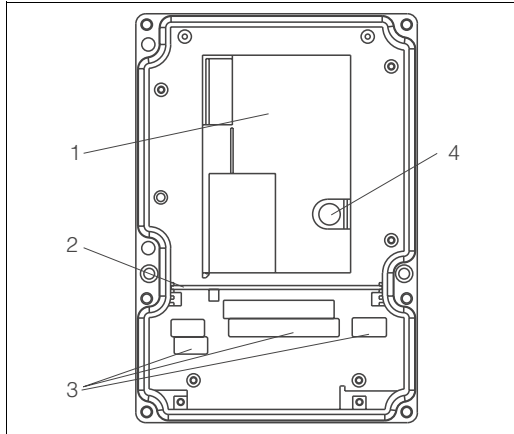

- 1 Removable electronics box
- 2 Partition plate
- 3 Terminals
- 4 Fuse

C07-OxM253xx-11-06-00-xx-001.eps

Fig. 3: View into the field housing

### 3.3.2 Panel-mounted instrument

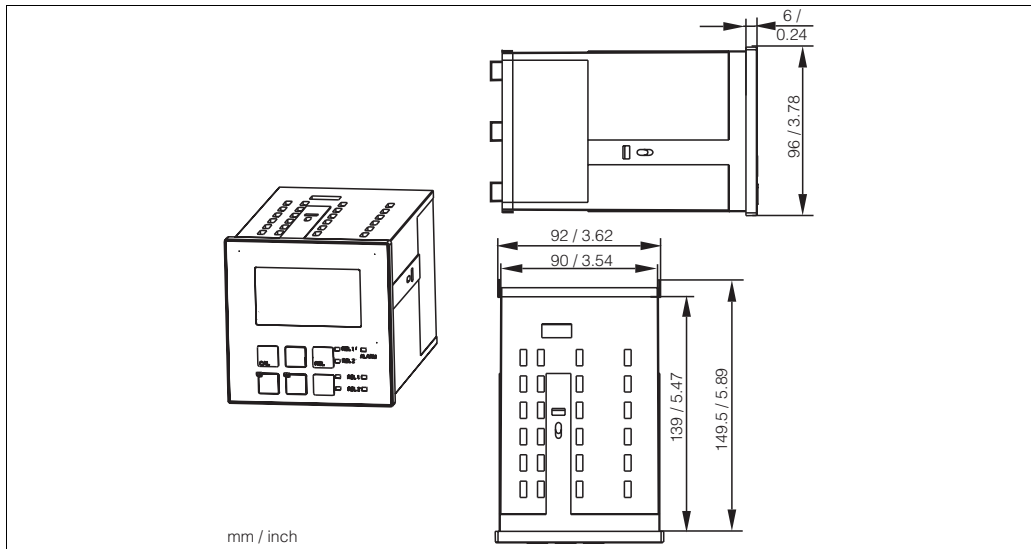

C07-OxM223xx-06-06-00-en-001.EPS

Fig. 4: Panel-mounted instrument

## 3.4 Installation instructions

### 3.4.1 Field instrument

There are several ways of securing the field housing:

- Wall mounting with fixing screws
- Post mounting to cylindrical pipes
- Post mounting to square securing mast



Note!

When mounting in the open air with unprotected exposure to weather conditions, a weather protection cover (see Accessories) is required.

#### Transmitter wall mounting

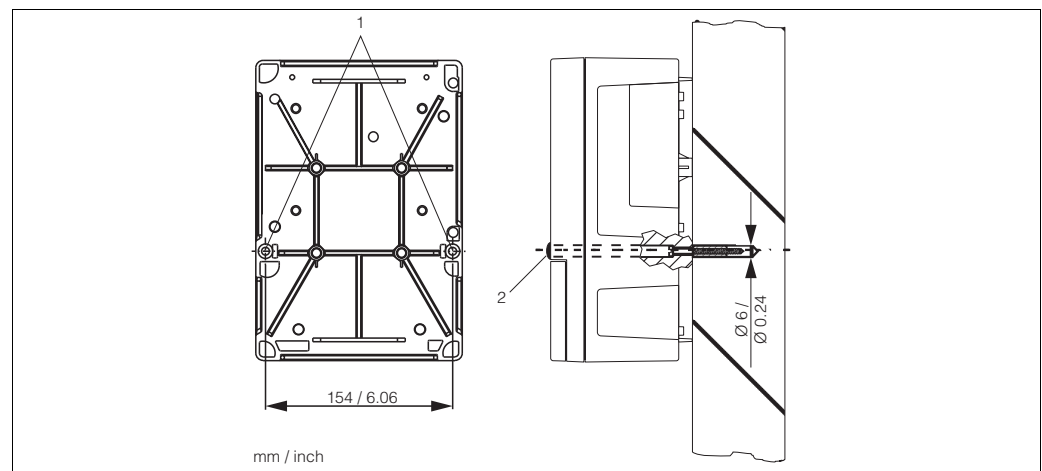

C07-OxM253-11-06-00-en-002.eps

Fig. 5: Field instrument wall mounting

For wall mounting the transmitter, proceed as follows:

1. Drill the bores as shown in Fig. 5.
2. Drive the two fixing screws through the securing bores (1) from the front.
3. Mount the transmitter on the wall as shown.
4. Cover the bores with plastic caps (2).

## Transmitter post mounting



### Note!

You require a post mounting kit to secure the field device to horizontal and vertical posts or pipes (max.  $\varnothing$  60 mm (2.36")). This can be acquired as an accessory (see "Accessories" section).

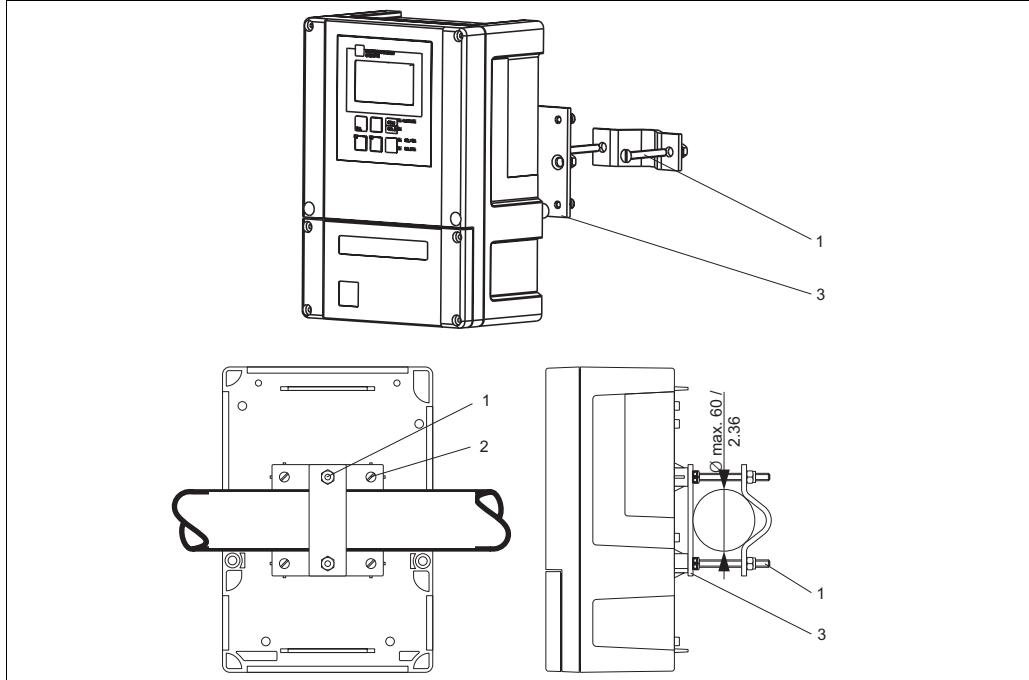

C07-0xM253xx-11-06-00-en-003.eps

Fig. 6: Post mounting field device to cylindrical pipes

For post mounting the transmitter, proceed as follows:

1. Guide the two securing screws (1) of the mounting kit through the openings of the securing plate (3).
2. Screw the securing plate onto the transmitter using the four fixing screws (2).
3. Secure the retainer with the field device using the clip on the post or pipe.

You can also secure the field device to a square universal post in conjunction with the weather protection cover. These can be acquired as accessories, see "Accessories" section.

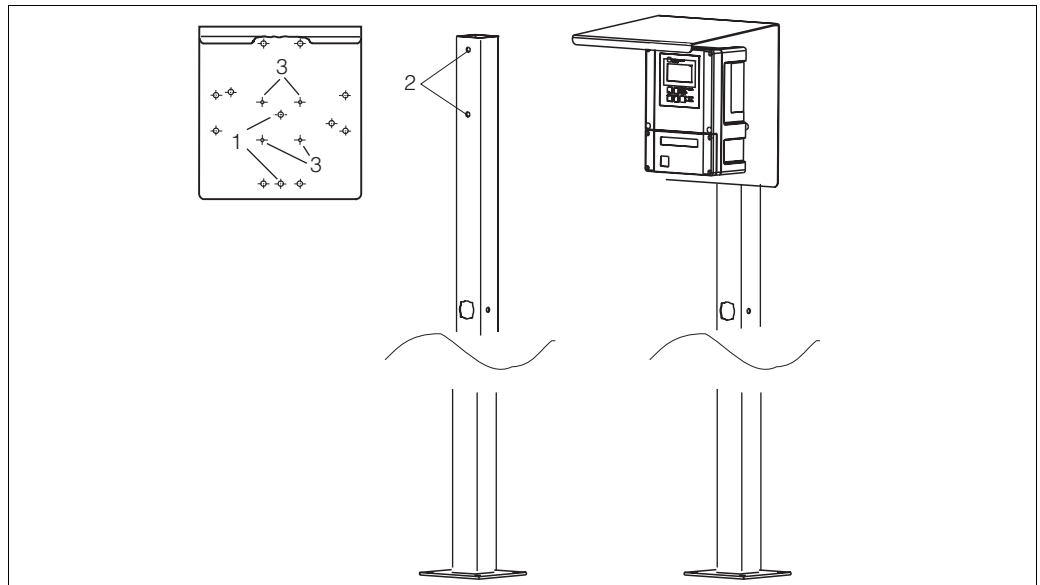

C07-CxM253xx-11-06-00-xx-004.eps

Fig. 7: Mounting field device with universal posts and weather protection cover

For mounting the weather protection cover, proceed as follows:

1. Screw the weather protection cover with 2 screws (bores 1) to the upright post (bores 2).
2. Secure the field device to the weather protection cover. To do so, use the bores (3).

### 3.4.2 Panel-mounted instrument

The panel-mounted instrument is secured with the clamping screws supplied (see → Fig. 8). The necessary installation depth is approx. 165 mm (6.50").

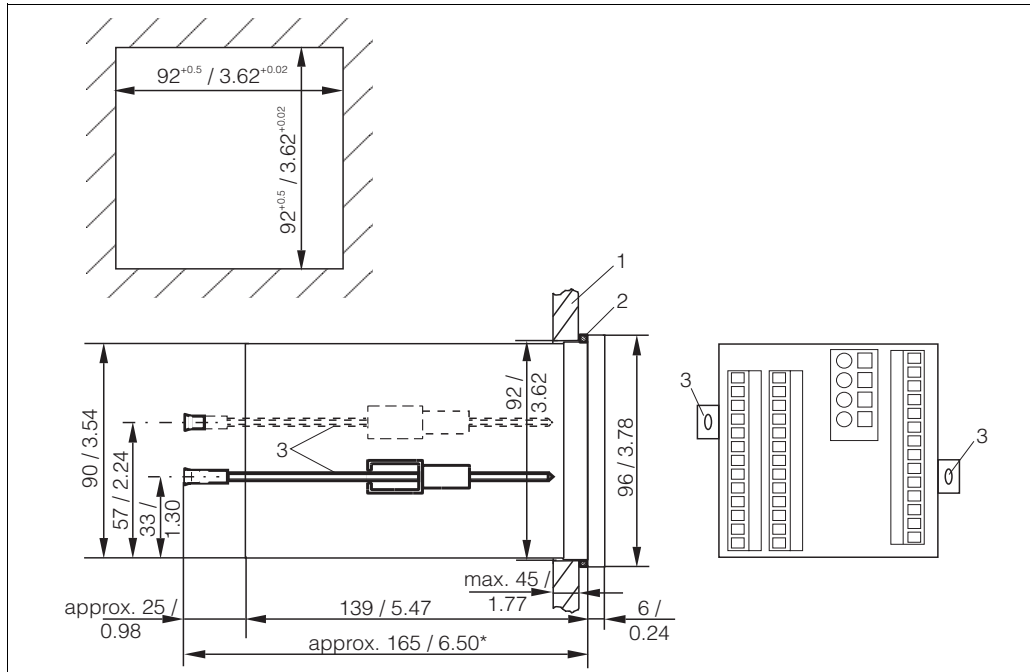

C07-OLM223xx-11-06-00-en-001.eps

Fig. 8: Securing the panel-mounted instrument

- 1 Wall of the cabinet
- 2 Seal
- 3 Clamping screws
- \* Required installation depth

### 3.5 Post-installation check

- After installation, check the transmitter for damage.
- Check whether the transmitter is protected against moisture and direct sunlight.



## 4 Wiring

### Warning!

- The electrical connection must only be carried out by authorised technical personnel.
- Technical personnel must have read and understood the instructions in this manual and must adhere to them.
- Ensure that there is no voltage at the power cable before beginning the connection work.

## 4.1 Electrical connection

### 4.1.1 Connection diagram

The wiring diagram depicted in Fig. 9 shows the connections of an instrument equipped with all the options. Connecting the sensors and the various measuring cables is explained in more detail in the "Measuring cables and sensor connection" section.

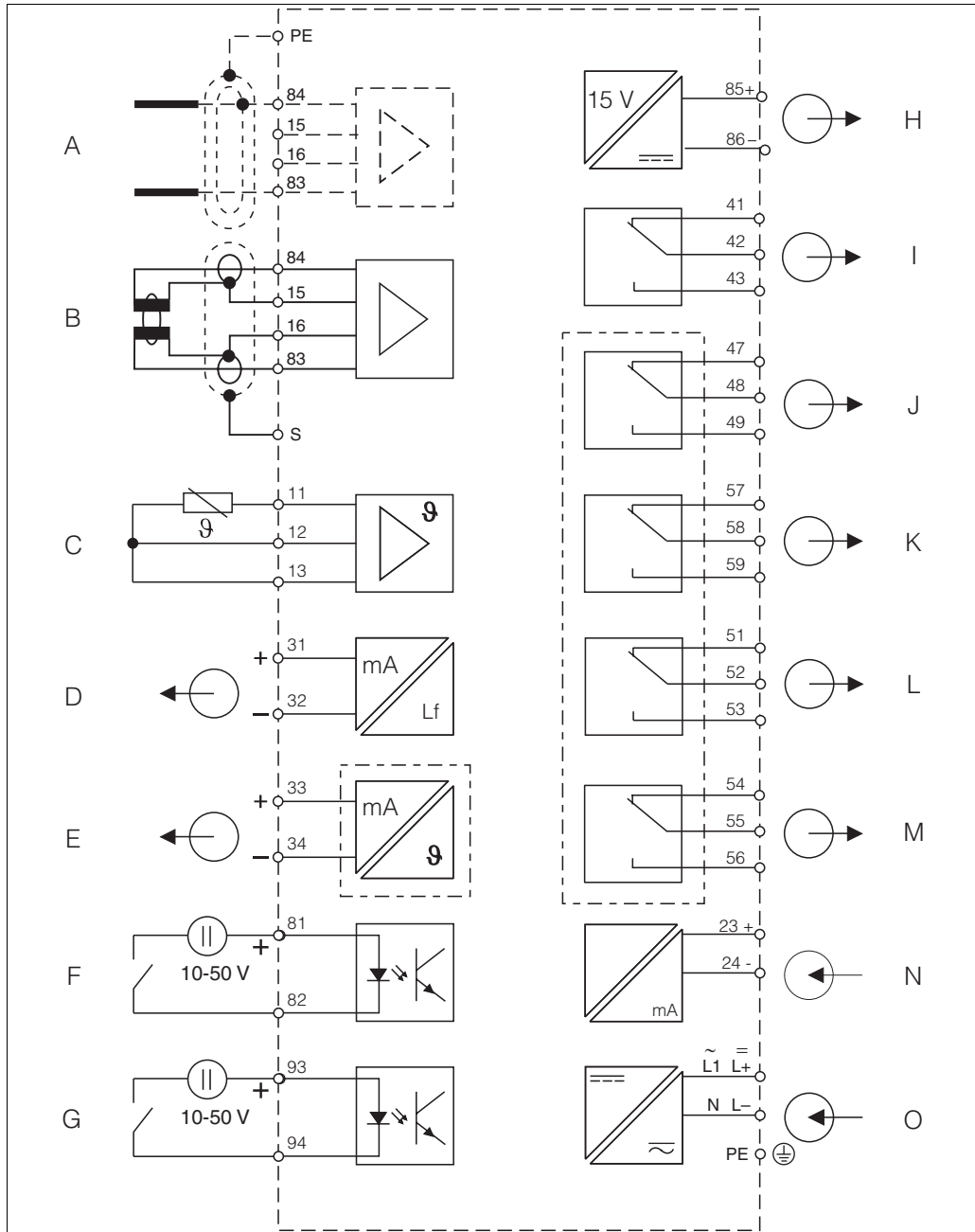

C07-OLM2x3xx-04-06-00-xx-001.eps

Fig. 9: Electrical connection of the transmitter

- |   |                              |   |   |
|---|------------------------------|---|---|
| A | Sensor (conductive)          | I | Alarm (current-free contact position)   |
| B | Sensor (inductive)           | J | Relay 1 (current-free contact position) |
| C | Temperature sensor           | K | Relay 2 (current-free contact position) |
| D | Signal output 1 conductivity | L | Relay 3 (current-free contact position) |
| E | Signal output 2 variable     | M | Relay 4 (current-free contact position) |
| F | Binary input 1 (Hold)        | N | Current input 4 ... 20 mA               |
| G | Binary input 2 (Chemoclean)  | O | Power supply                            |
| H | Aux. voltage output          |   |   |



**Note!**

- The device is approved for protection class II and is generally operated without a protective earth connection.
- To guarantee measuring stability and functional safety, you have to ground the outer screen of the sensor cable:
  - Inductive sensors: terminal "S"
  - Conductive sensors: PE distributor rail
 This is on the cover frame for panel-mounted instruments and in the connection compartment for field devices. Ground the PE distributor rail or the ground terminal.
- The circuits "E" and "H" are not galvanically isolated from each other.

**Field instrument connection**

Guide the measuring cables through the PG glands into the housing. Connect the measuring cables in accordance with the terminal assignment (Fig. 10).

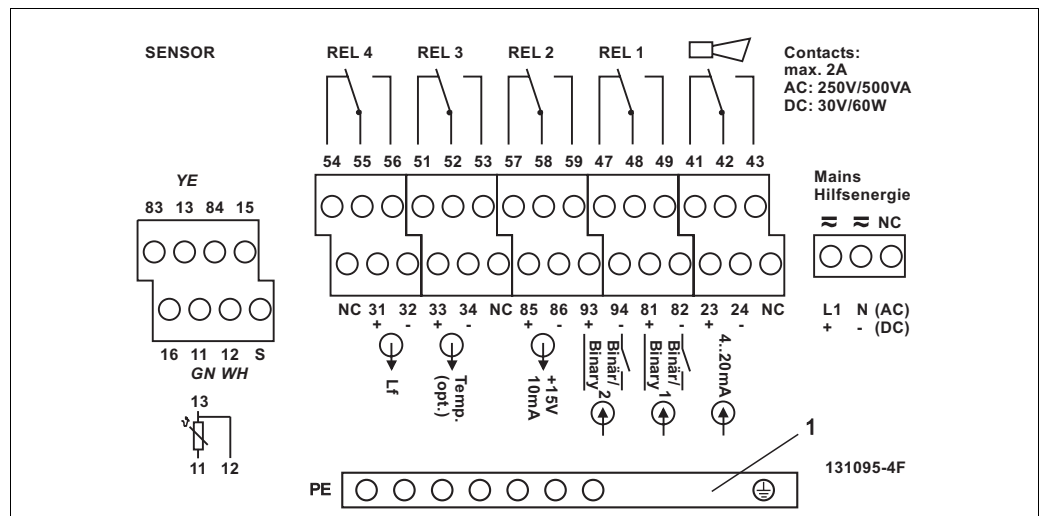

C07-OLM253xx-04-06-00-xx-002.eps

Fig. 10: Field instrument connection compartment sticker

1 PE distributor rail for CD/CS version (conductive sensors)

**Panel-mounted instrument connection**

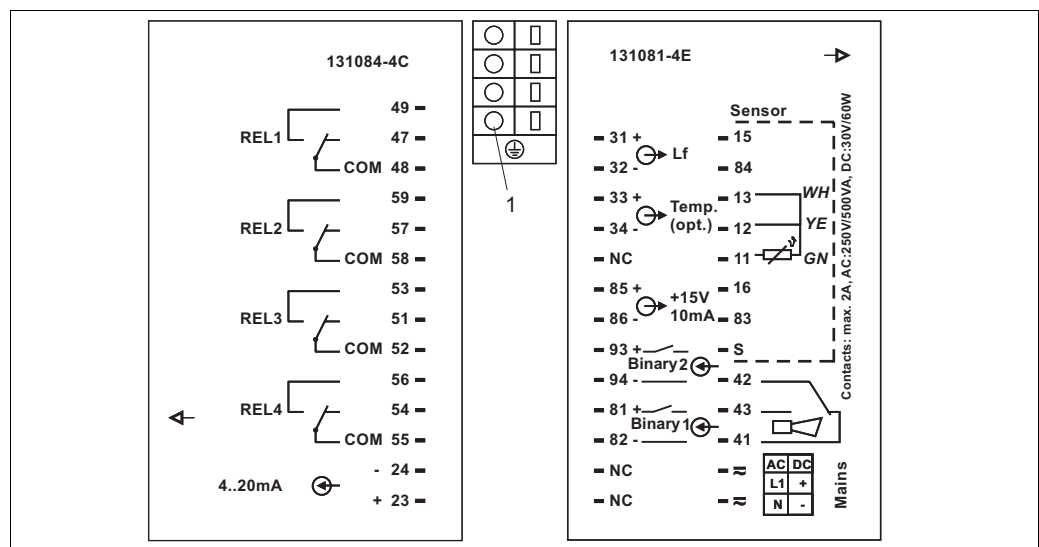

C07-OLM223xx-04-06-00-xx-003.eps

Fig. 11: Panel-mounted instrument connection sticker

1 Ground terminal



**Caution!**

- Terminals marked NC may not be wired.
- Unmarked terminals may not be wired.



**Note!**

Please label the sensor terminal block with the sticker provided.

**4.1.2 Measuring cable and sensor connection**

You require screened special measuring cables to connect conductivity sensors to the transmitter. The following multi-core and ready-to-use cable types can be used:

Sensor type	Cable	Extension
Two-electrode sensors with or without temperature sensor Pt 100	OYK71 OPK9* (for OLS16)	Junction box VBM + OYK71
Inductive sensors OLS50, OLS52	Cable permanently attached to sensor	Junction box VBM + OLK5

\* High-temperature version without PML

Maximum cable length	
Conductivity measurement (conductive)	max. 100 m (328 ft) with OYK71
Resistivity measurement	max 15 m (49.22 ft) with OYK71
Conductivity measurement (inductive)	max. 55 m (180.46 ft) with OLK5 (sensor cable incl.)

**Structure and termination of the measuring cables**

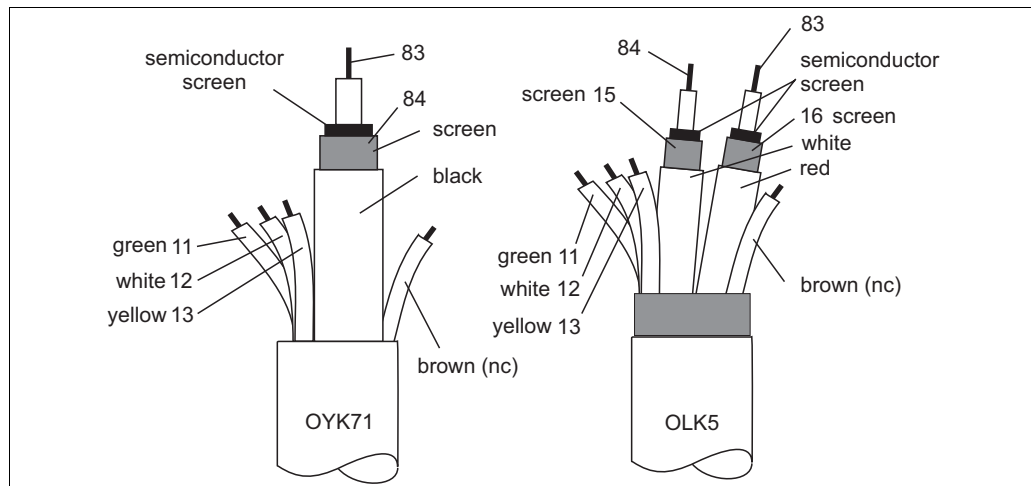

C07-OLM2x3xx-04-06-00-en-004.eps

Fig. 12: Structure of the special measuring cables

- A Semiconductor layer
- sc Screening



**Note!**

For further information on the cables and junction boxes, please refer to the "Accessories" section.

**Field instrument measuring cable connection**

Proceed as follows to connect a conductivity sensor to the field instrument:

1. Open the housing cover to access the terminal block in the connection compartment.
2. Break the punching of a cable gland from the housing, mount a cable gland and guide the cable through this cable gland.
3. Connect the cable in accordance with the terminal assignment (see connection compartment sticker).
4. Tighten the cable gland.

**Panel-mounted instrument measuring cable connection**

To connect a conductivity sensor, connect the measuring cable in accordance with the terminal assignment to the terminals on the rear of the device (see connection sticker).

**Example of connecting a conductivity sensor**

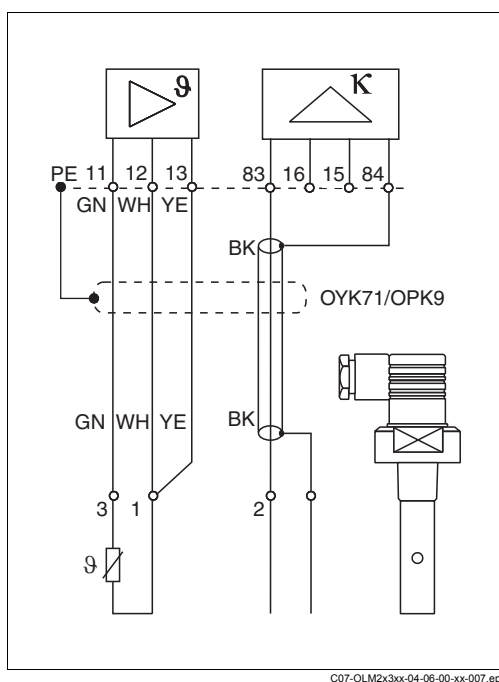

Fig. 13: Connection of conductive sensors

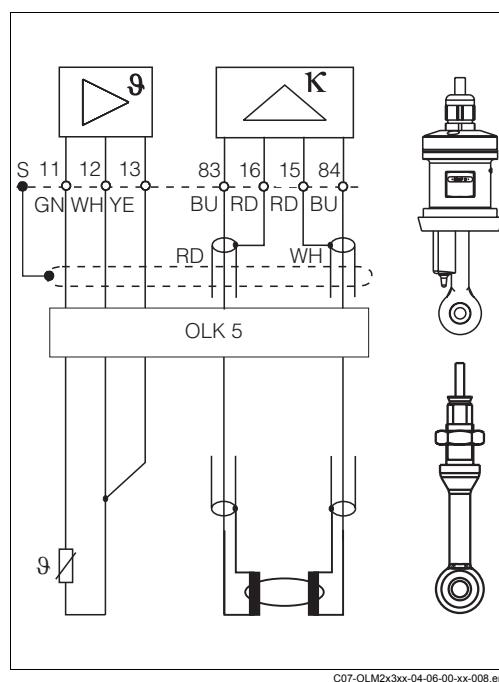

Fig. 14: Connection of inductive sensors

### 4.1.3 Alarm contact

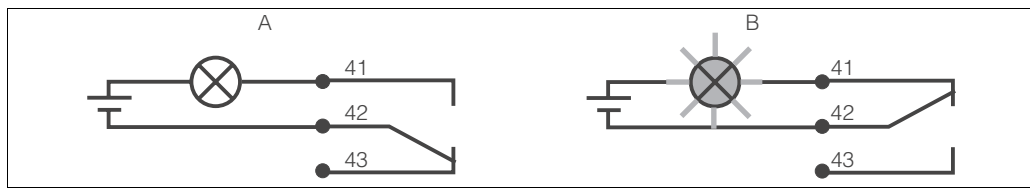

Fig. 15: Recommended fail-safe switching for the alarm contact

A Normal operating status

B Alarm condition

#### Normal operating status:

- Device in operation
- No error message present (Alarm LED off)
- › Relay energised
- › Contact 42/43 closed

#### Alarm condition

- Error message present (alarm LED red) or
- Device defective or voltage-free (alarm LED off)
- › Relay de-energised
- › Contact 41/42 closed

## 4.2 Post-connection check

After wiring up the electrical connection, carry out the following checks:

Device status and specifications	Remarks
Are the transmitter or the cable externally damaged?	Visual inspection

Electrical connection	Remarks
Are the installed cables strain-relieved?	
No loops and cross-overs in the cable run?	
Are the signal cables correctly connected acc. to the wiring diagram?	
Are all screw terminals tightened?	
Are all cable entries installed, tightened and sealed?	
Are the PE distributor rails grounded (if present)?	Grounding at place of installation

## 5 Operation

### 5.1 Quick operation guide

You have the following ways of operating the transmitter:

- On site via the key field
- Via the HART® interface (optional, with corresponding order version) per:
  - HART® handheld terminal or
  - PC with HART® modem and the Commuwin II software package
- Via PROFIBUS PA/DP (optional, with corresponding order version) with:
  - PC with corresponding interface and the Commuwin II software package (see Accessories)
  - or via a programmable logic controller (PLC)



Note!

For operation via HART or PROFIBUS PA/DP, please read the relevant sections in the additional Operating Instructions:

- PROFIBUS PA/DP, field communication for OXM223/253, BA209e00
- HART®, field communication for OXM223/253, BA208e00

The following section only explains operation via the keys.

### 5.2 Display and operating elements

#### 5.2.1 Display

##### LED display

	Indicates the current operating mode, "Auto" (green LED) or "Manual" (yellow LED)
	Indicates the activated relay in the "Manual" mode (red LED)
REL 1 <input type="checkbox"/> REL 2 <input type="checkbox"/>	Indicates the working status of relay 1 and 2 LED green: measured value within the permitted limit, relay inactive LED red: measured value outside the permitted limit, relay active
ALARM <input type="checkbox"/>	Alarm display, e.g. for continuous limit value overshoot, temperature sensor failure or system error (see error list)

LC display

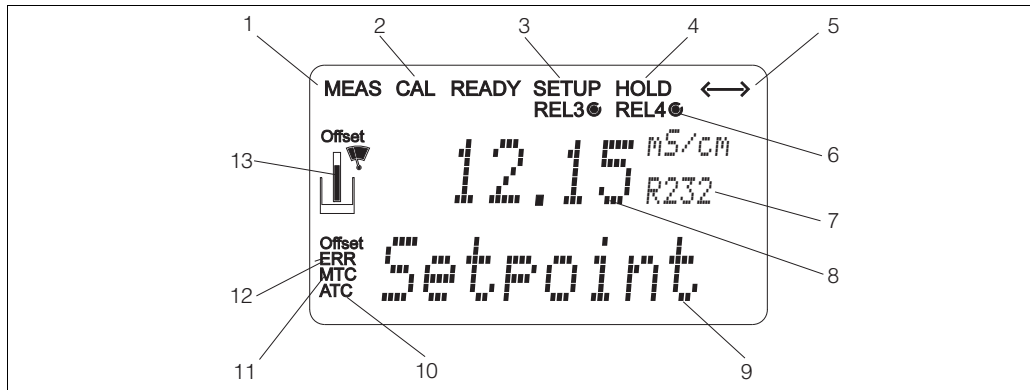

C07-OLM2x3xx-07-06-00-en-004.eps

Fig. 16: LC display transmitter

- |   |  |    |  |
|---|--|----|--|
| 1 | Indicator for measuring mode (normal operation)                          | 8  | In measuring mode: measured variable<br>In setup mode: configured variable |
| 2 | Indicator for calibration mode   | 9  | Indicator for autom. temperature compensation                              |
| 3 | Indicator for setup mode (configuration)                                 | 11 | Indicator for man. temperature compensation                                |
| 4 | Indicator for "Hold" mode (current outputs remain at last current state) | 12 | "Error": error display   |
| 5 | Indicator for receipt of a message for devices with communication        | 13 | Sensor symbol  |
| 6 | Indicator of working status of relays 3/4:<br>○ inactive, ● active       |    |  |
| 7 | Function code display  |    |  |

5.2.2 Operating elements

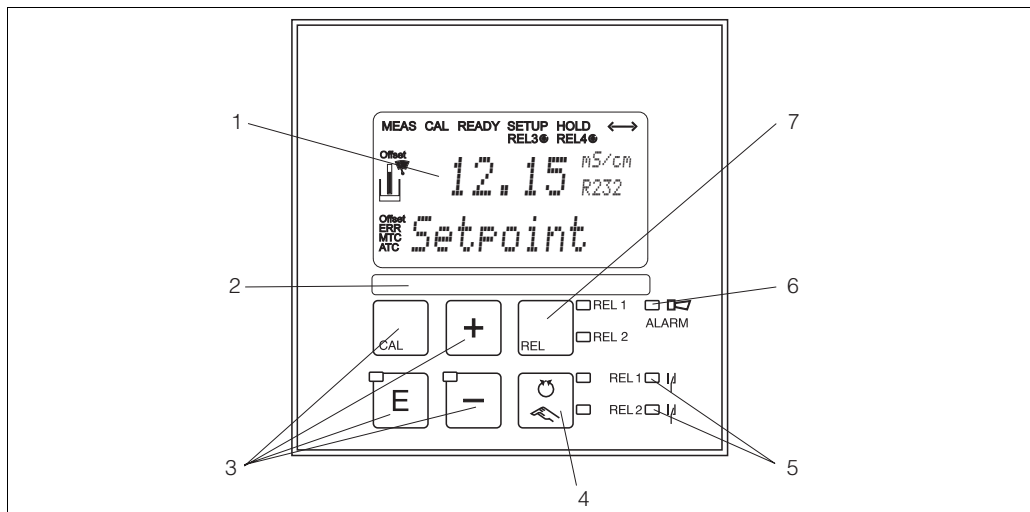









C07-OLM2x3xx-19-06-01-en-001.eps

Fig. 17: Operating elements

- |   |   |
|---|---|
| 1 | LC display for displaying the measured values and configuration data      |
| 2 | Field for user labelling  |
| 3 | 4 main operating keys for calibration and device configuration            |
| 4 | Changeover switch for automatic/manual mode of the relays                 |
| 5 | LEDs for limit contactor relay (switch status)                            |
| 6 | LED for alarm function  |
| 7 | Display of the active contact and key for relay changeover in manual mode |

### 5.2.3 Key assignment

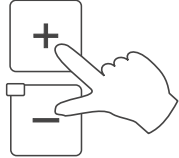
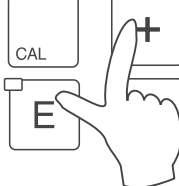
	<p><b>CAL key</b> When you press the CAL key, the device first prompts you for the calibration access code:</p> <ul style="list-style-type: none"> <li>• Code 22 for calibration</li> <li>• Code 0 or any other code for reading the last calibration data</li> </ul> <p>Use the CAL key to accept the calibration data or to switch from field to field within the calibration menu.</p>
	<p><b>ENTER key</b> When you press the ENTER key, the device first prompts you for the setup mode access code:</p> <ul style="list-style-type: none"> <li>• Code 22 for setup and configuration</li> <li>• Code 0 or any other code for reading all configuration data.</li> </ul> <p>The ENTER key has several functions:</p> <ul style="list-style-type: none"> <li>• Calls up the Setup menu from the measuring mode.</li> <li>• Saves (confirms) data entered in the setup mode.</li> <li>• Moves on within function groups.</li> </ul>
 	<p><b>PLUS key and MINUS key</b> In the setup mode, the PLUS and MINUS keys have the following functions:</p> <ul style="list-style-type: none"> <li>• Selection of function groups.</li> </ul> <p> <b>Note!</b> Press the MINUS key to select the function groups in the order given in the "System configuration" section.</p> <ul style="list-style-type: none"> <li>• Configuration of parameters and numerical values</li> <li>• Operation of the relay in manual mode</li> </ul> <p>In the measuring mode, you get the following sequence of functions by <b>repeatedly pressing the PLUS key</b>:</p> <ol style="list-style-type: none"> <li>1. Temperature display in F</li> <li>2. Temperature display hidden</li> <li>3. Current input signal in %</li> <li>4. Current input signal in mA</li> <li>5. Display of the uncompensated conductivity</li> <li>6. Return to basic settings</li> </ol> <p>In the measuring mode, the following is displayed in sequence by <b>repeatedly pressing the MINUS key</b>:</p> <ol style="list-style-type: none"> <li>1. Current errors are displayed in rotation (max. 10).</li> <li>2. Once all the errors have been displayed, the standard measurement display appears. In the function group F, an alarm can be defined separately for each error code.</li> </ol>





 <p>REL 1 REL 2</p>	<p><b>REL key</b>                  In the manual mode, you can use the REL key to switch between the relay and the manual start of cleaning.                  In the automatic mode, you can use the REL key to read out the switch-on points (for limit contactor) or set points (for PID controller) assigned to the relay in question.                  Press the PLUS key to jump to the settings of the next relay. Use the REL key to get back to the display mode (automatic return after 30 s).</p>
	<p><b>AUTO key</b>                  You can use the AUTO key to switch between automatic mode and manual mode.</p>
	<p><b>Escape function</b>                  If you press the PLUS and MINUS key simultaneously, you return to the main menu or are taken to the end of calibration if calibrating. If you press the PLUS and MINUS key again, you return to the measuring mode.</p>
	<p><b>Locking the keyboard</b>                  Press the PLUS and ENTER key for at least 3 s to lock the keyboard against any unauthorised data entry. All the settings can continue to be read.                  The code prompt displays the code 9999.</p>
	<p><b>Unlocking the keyboard</b>                  Press the CAL and MINUS key for at least 3 s to unlock the keyboard.                  The code prompt displays the code 0.</p>

## 5.3 Local Operation

### 5.3.1 Automatic/manual mode

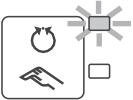
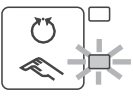
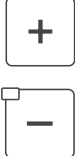
The transmitter normally operates in automatic mode. Here, the relays are triggered by the transmitter. In the manual mode, you can trigger the relays using the REL key or start the cleaning function.

How to change the operating mode:

	<p>1. The transmitter is in <b>Automatic mode</b>. The top LED beside the AUTO key is lit.</p>
	<p>2. Press the AUTO key. The bottom LED beside the AUTO key lights up.</p>
	<p>3. To enable the manual mode, enter the code <b>22</b> via the PLUS and MINUS keys.</p>
	<p>4. Select the relay or the function. You can use the REL key to switch between the relays. The relay selected and the switch status (ON/OFF) is displayed on the second line of the display. In the manual mode, the measured value is displayed continuously (e.g. for measured value monitoring for dosing functions).</p>
	<p>5. Switch the relay. It is switched on with PLUS and switched off with MINUS. The relay remains in its switched state until it is switched over again.</p>
	<p>6. Press the AUTO key to return to the measuring mode, i.e. to the automatic mode. All the relays are triggered again by the transmitter.</p>



#### Note!

- The operating mode remains in effect even after a power failure.
- The manual mode has priority over all other automatic functions (Hold).
- Hardware locking is not possible in the manual mode.
- The manual settings are kept until they are actively reset.
- Error code E102 is signalled in the manual mode.

## 5.3.2 Operating concept

### Operating modes

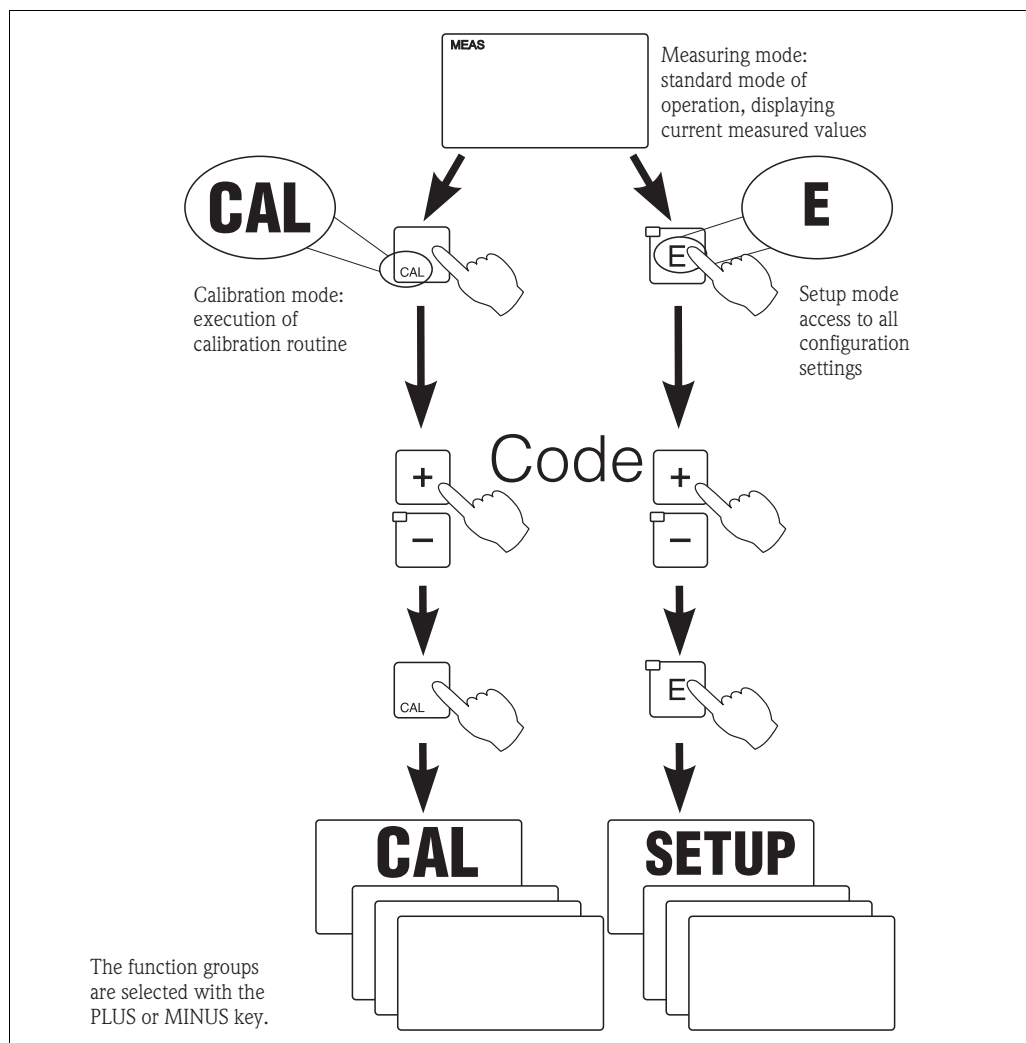

C07-OxM2x3xx-19-06-00-en-001.eps

Fig. 18: Description of the possible operating modes



#### Note!

If no key is pressed in the setup mode for approx. 15 min, the device automatically returns to the measuring mode. Any active Hold (Hold during setup) is reset.

#### Access codes

All device access codes are fixed and cannot be altered. When the device requests the access code, it distinguishes between different codes.

- **Key CAL + Code 22:** access to Calibration and Offset menu
- **Key ENTER + Code 22:** access to the menus for the parameters which make configuration and user-specific settings possible
- **Keys PLUS + ENTER:** locks the keyboard
- **Keys CAL + MINUS:** unlocks the keyboard
- **Key CAL or ENTER + any code:** access to read mode, i.e. all the settings can be read but not modified.

The device continues measuring in the read mode. It does not shift to the Hold status. The current output and the controllers remain active.

## Menu structure

The configuration and calibration functions are arranged in function groups.

- In the setup mode, select a function group with the PLUS and MINUS keys.
- In the function group itself, switch from function to function with the ENTER key.
- Within the function, select the desired option with the PLUS and MINUS keys or edit the settings with these keys. Then confirm with the ENTER key and continue.
- Press the PLUS and MINUS keys simultaneously (Escape function) to exit programming (return to the main menu).
- Press the PLUS and MINUS simultaneously keys again to switch to the measuring mode.



Note!

- If a modified setting is not confirmed with ENTER, the old setting is retained.
- An overview of the menu structure is provided in the Appendix to these Operating Instructions.

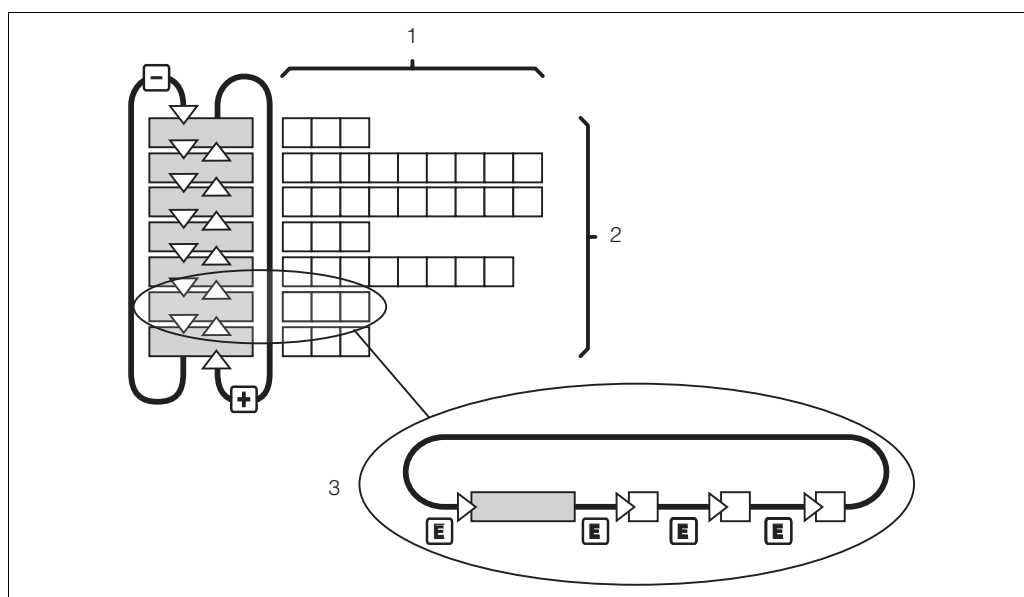

C07-OxM2x3xx-19-06-00-xx-002.eps

Fig. 19: Diagram of the menu structure

- 1 Functions (parameters selected, numbers entered)
- 2 Function groups, scroll backwards and forwards with the PLUS and MINUS keys
- 3 Switch from function to function with the ENTER key

## Hold function: "freezing" of the outputs

In both the setup mode and during calibration, the current output can be "frozen", it constantly retains its current status. "HOLD" appears on the display. If the controller actuating variable (steady control 4 ... 20 mA) is output via current output 2, it is set to 0/4 mA in Hold.



Note!

- Hold settings can be found in the "Service" section.
- During Hold, all contacts will go to their normal positions.
- An active Hold has priority over all other functions.
- With every Hold, the I-component of the controller is set to zero.
- Any alarm delay is reset to "0".
- This function can also be activated externally via the Hold input (see Wiring diagram; binary input 1).
- The manual Hold (field S3) remains active even after a power failure.

## 6 Commissioning

### 6.1 Function check



Warning!

- Check all connections for correctness.
- Make sure that the supply voltage is identical to the voltage written on the nameplate!

### 6.2 Switching on

Familiarise yourself with the operation of the transmitter before it is first switched on. Please refer in particular to the "Safety instructions" and "Operation" sections.

After power-up, the device performs a self-test and then goes to the measuring mode.

Now calibrate the sensor in accordance with the instructions in the "Calibration" section.



Note!

During commissioning, the sensor must be calibrated so that the measuring system can return precise measurement data.

Then perform the first configuration in accordance with the instructions in the "Quick start-up" section. The values set by the user are kept even in the event of a power failure.

The following function groups are available in the transmitter (the groups only available in the Plus Package are marked accordingly in the functional description):

#### Setup mode

- SETUP 1 (A)
- SETUP 2 (B)
- CURRENT INPUT (Z)
- CURRENT OUTPUT (O)
- ALARM (F)
- CHECK (P)
- RELAY (R)
- TEMPERATURE COMPENSATION (T)
- CONCENTRATION MEASUREMENT (K)
- SERVICE (S)
- SERVICE 2(E)
- INTERFACE (I)

#### Calibration mode

- CALIBRATION (C)



Note!

A detailed explanation of the function groups available in the transmitter can be found in the "System configuration" section.

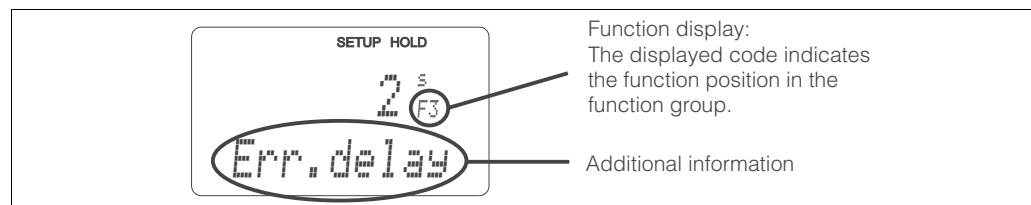

C07-OLD132xx-07-06-00-en-003.eps

Fig. 20: Example for display in setup mode

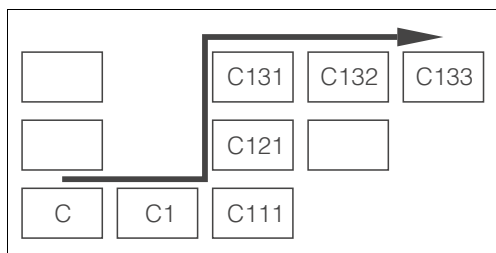

C07-OLD132xx-13-06-00-xx-005.eps

Fig. 21: Function coding

Selecting and locating functions is facilitated by a code displayed for each function in a special display field Fig. 20. The structure of this coding is given in Fig. 21.

The first column indicates the function group as a letter (see group designations). The functions in the individual groups are counted from the top to the bottom and from the left to the right.

### Factory settings

The first time it is switched on, the device has the factory setting for all functions. The table below provides an overview of the most important settings.

All other factory settings can be found in the description of the individual function groups in the "System configuration" section (the factory setting is highlighted in **bold**).

Function	Factory setting
Type of measurement	Conductive conductivity measurement Temperature measurement in °C
Type of measurement compensation	Linear with reference temperature 25 C (77 °F)
Temperature compensation	Automatic (ATC on)
Limit value for controller 1	9999 mS/cm
Limit value for controller 2	9999 mS/cm
Hold	Active during configuration and calibration
Measuring range	0 µS/cm ... 2000 mS/cm (no measuring ranges for setting). The setting is flowing and is guided by the connected sensors.
Current outputs 1* and 2*	4 ... 20 mA
Current output 1: measured value for 4 mA signal current*	0 µS/cm
Current output 1: measured value for 20 mA signal current*	2000 mS/cm
Current output 2: temperature value for 4 mA signal current*	-35.0 C (-31 °F)
Current output 2: temperature value for 20 mA signal current*	250.0 C (482 °F)







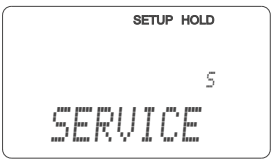
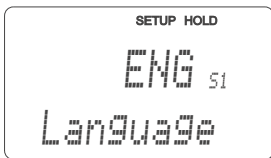
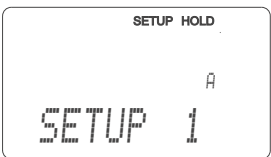
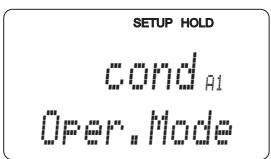
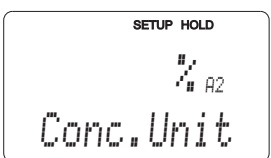
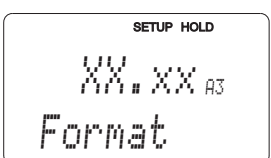
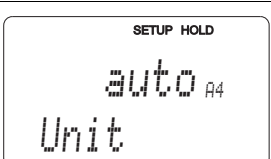





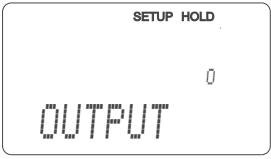

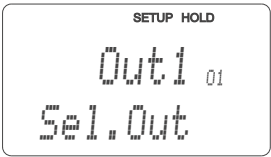
\* For corresponding version

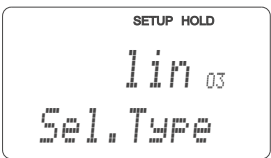
### 6.3 Quick start-up

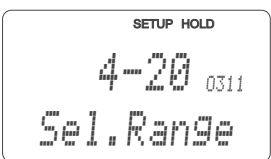
After power-up, you must make some settings to configure the most important functions of the transmitter which are required for correct measurement. The following section gives an example of this.

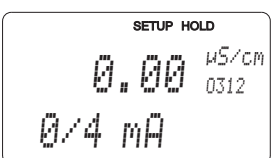
User input	Setting range (Factory settings, bold)	Display
1. Press the <b>E</b> key. 2. Enter the code 22 to edit the setup. Press <b>E</b> .		
3. Press <b>-</b> until you get to the "Service" function group. 4. Press <b>E</b> to be able to make your settings.		
5. In S1, select your language, e.g. "ENG" for English. Press <b>E</b> to confirm.	<b>ENG = English</b> GER = German FRA = French ITA = Italian NEL = Dutch ESP = Spanish	
6. Press <b>+/-</b> simultaneously to exit the "Service" function group.		
7. Press <b>-</b> until you get to the "Setup 1" function group. 8. Press <b>E</b> to be able to make your settings for "Setup 1".		
9. In A1, select the desired mode of operation, e.g. "cond" = conductive. Press <b>E</b> to confirm.	<b>cond = conductive</b> ind = inductive MOhm = resistivity conc = concentration	
10. In A2, press <b>E</b> to confirm the factory settings. (if A1 = conc, else step 12)	% ppm mg/l TDS = Total Dissolved Solids none	
11. In A3, press <b>E</b> to confirm the factory settings.	<b>XX.xx</b> X.xxx XXX.x XXXX	
12. In A4, press <b>E</b> to confirm the factory settings.	<b>auto</b> , µS/cm, mS/cm, S/cm, µS/m, mS/m, S/m	

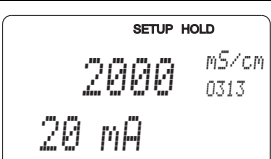
User input	Setting range (Factory settings, bold)	Display
13. In A5, enter the cell constant of the connected sensor. Refer to the sensor's quality certificate for the exact value.	cond: <b>1.000</b> cm <sup>-1</sup> ind: <b>1.98</b> cm <sup>-1</sup> MOhm: <b>0.01</b> cm <sup>-1</sup> 0.0025 ... 99.99 cm <sup>-1</sup>	<div style="border: 1px solid black; padding: 5px; text-align: center;">                     SETUP HOLD                      1.000<sup>1/cm</sup><sub>A5</sub>                      Cellconst                 </div>
14. In A6, enter the resistance of the cable (conductive sensors only).	<b>0</b> Ω 0 ... 99.99 Ω	<div style="border: 1px solid black; padding: 5px; text-align: center;">                     SETUP HOLD                      0<sup>Ω</sup><sub>A6</sub>                      Cable-Res                 </div>
15. If you need to stabilise the display, enter the required damping factor in A7. Press <b>E</b> to confirm. The display returns to the initial display of "Setup 1"	<b>1</b> 1 ... 60	<div style="border: 1px solid black; padding: 5px; text-align: center;">                     SETUP HOLD                      1<sub>A7</sub>                      Damping                 </div>
16. Press <b>-</b> to go to the "Setup 2" function group 17. Press <b>E</b> to edit "Setup 2"		<div style="border: 1px solid black; padding: 5px; text-align: center;">                     SETUP HOLD                      B                      SETUP 2                 </div>
18. In B1, select your temperature sensor. Press <b>E</b> to confirm.	<b>Pt 100</b> Pt 1k = Pt 1000 NTC30 fixed	<div style="border: 1px solid black; padding: 5px; text-align: center;">                     SETUP HOLD                      Pt100<sub>B1</sub>                      ProcTemp.                 </div>
19. In B2, select the appropriate temperature compensation for your process, e.g. "lin" = linear. Press <b>E</b> to confirm your selection. For detailed information on temperature compensation, see chapter "Setup 2"	none <b>lin = linear</b> NaCl = common salt (IEC 60746) Pure = ultra pure water NaCl PureH = ultra pure water HCl Tab = table	<div style="border: 1px solid black; padding: 5px; text-align: center;">                     SETUP HOLD                      lin<sub>B2</sub>                      TempComp.                 </div>
20. In B3, enter the temperature coefficient α. Press <b>E</b> to confirm.	<b>2.1</b> %/K 0.0 ... 20.0 %/K	<div style="border: 1px solid black; padding: 5px; text-align: center;">                     SETUP HOLD                      2.10<sup>%/K</sup><sub>B3</sub>                      Alpha val                 </div>
21. The real temperature is displayed in B5. If necessary, calibrate the temperature sensor to an external measurement. Press <b>E</b> to confirm.	Display and entry of real temperature -35.0 ... 250.0 °C fixed	<div style="border: 1px solid black; padding: 5px; text-align: center;">                     SETUP HOLD                      0.0<sup>°C</sup><sub>B5</sub>                      RealTemp.                 </div>
22. The difference between the measured and the entered temperatures is displayed. Press <b>E</b> . The display returns to the initial display of the "Setup 2" function group.	<b>0.0</b> °C -5.0 ... 5.0 °C	<div style="border: 1px solid black; padding: 5px; text-align: center;">                     SETUP HOLD                      0.0<sup>°C</sup><sub>B6</sub>                      TempOffs.                 </div>

User input	Setting range (Factory settings, bold)	Display
23. Press  to go to the "Current output" function group. 24. Press  to edit the output settings.		
25. In O1, select your output, e.g. "Out1" = output 1. Press  to confirm.	Out1 Out2	
26. In O3, select the linear characteristic. Press  to confirm.	<b>lin = linear (1)</b> sim = simulation Tab = table	
27. In O311, select the current range for your output, e.g. 4 ... 20 mA. Press  to confirm.	4 ... 20 mA 0 ... 20 mA	
28. In O312, enter the conductivity corresponding to the minimum current value at the transmitter output, e.g. 0 μS/cm. Press  to confirm.	cond/ind: <b>0.00 μS/cm</b> MOhm: <b>0.00 kΩ·cm</b> Conc: <b>0.00 %</b> Temp: <b>0.00 °C</b>	
29. In O313, enter the conductivity corresponding to the maximum current value at the transmitter output, e.g. 2000 mS/cm. Press  to confirm. The display returns to the initial display of the "Current output" function group.	cond/ind: <b>2000 mS/cm</b> MOhm: <b>500 kΩ·cm</b> Conc: <b>99.99 %</b> Temp: <b>150 °C</b>	
30. Press  simultaneously to switch to the measurement mode.		



**Note!**

For inductive sensors you must perform an airset before installation of the sensor, refer to the chapter "Calibration"

## 6.4 System configuration

### 6.4.1 Setup 1 (Conductivity)

In the SETUP 1 function group, you can change the operating mode and the sensor settings. Basic version does not include functions in *italic*.

Coding	Field	Selection or range (factory settings bold)	Display	Info
A	Function group SETUP 1			Basic settings.
A1	Select operating mode	<b>cond</b> = conductive ind = inductive MOhm = resistivity <i>conc</i> = concentration		Display varies depending on instrument version: – cond/resistivity/conc – ind/conc Caution! Any change in operating mode causes an automatic reset of user settings.
A2	Select concentration unit to be displayed (only with Plus Package)	% <i>ppm</i> <i>mg/l</i> TDS = Total Dissolved Solids <i>none</i>		A2 only active if A1 = conc.
A3	Select display format for concentration unit (only with Plus Package)	<b>XX.xx</b> <i>X.xxx</i> <i>XXX.x</i> <i>XXXX</i>		A3 only active if A1 = conc.
A4	Select unit to be displayed	<b>auto</b> , $\mu\text{S/cm}$ , $\text{mS/cm}$ , $\text{S/cm}$ , $\mu\text{S/m}$ , $\text{mS/m}$ , $\text{S/m}$ , $\text{k}\Omega\text{-cm}$ , $\text{M}\Omega\text{-cm}$ , $\text{k}\Omega\text{-m}$		When “auto” is selected, the maximum resolution possible is automatically selected. A4 not active if A1 = conc.
A5	Enter cell constant for connected sensor	cond: <b>1.000</b> $\text{cm}^{-1}$ ind: <b>1.98</b> $\text{cm}^{-1}$ MOhm: <b>0.01</b> $\text{cm}^{-1}$ 0.0025 ... 99.99 $\text{cm}^{-1}$		For the exact value of the cell constant, refer to the quality certificate.
A6	Enter cable resistance	<b>0</b> $\Omega$ 0 ... 99.99 $\Omega$		Only with conductive sensors. Multiply the standardised line resistance by the actual cable length. OYK71: 0.165 $\Omega/\text{m}$
A7	Enter measured value damping	<b>1</b> 1 ... 60		Measured value damping causes averaging over the specified number of individual measured values. It is used, for example, to stabilise the display with applications that fluctuate a great deal. There is no damping if “1” is entered.

### 6.4.2 Setup 2 (Temperature)

The temperature coefficient  $\alpha$  specifies the change in conductivity per degree of temperature change:

$$\kappa(T) = \kappa(T_0) \cdot (1 + \alpha \cdot (T - T_0))$$

with

$\kappa(T)$  = conductivity at process temperature T

$\kappa(T_0)$  = conductivity at reference temperature  $T_0$

The temperature coefficient depends on the chemical composition of the medium and the temperature itself.

In order to compensate for this dependence, four different compensation types can be selected in the transmitter:

- Linear temperature compensation
- NaCl compensation
- Ultrapure water compensation NaCl (neutral compensation)
- Ultrapure water compensation HCl (acid compensation)
- Temperature compensation with table

#### Linear temperature compensation

The change between two temperature points is considered to be constant, i.e.  $\alpha = \text{const}$ . The  $\alpha$  value can be edited for the linear compensation type. You can edit the reference temperature in field B7, the factory setting is 25 °C/77 °F.

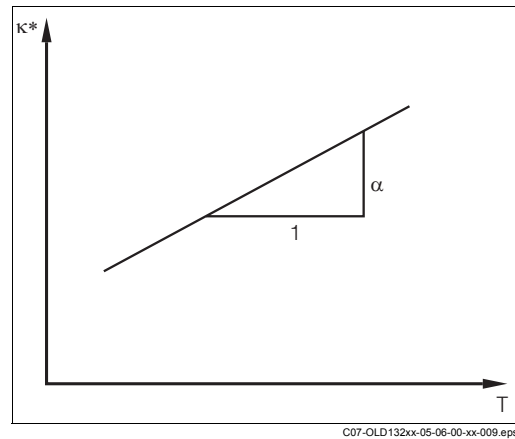

Fig. 22: Linear temperature compensation

\* uncompensated conductivity

#### NaCl compensation

The NaCl compensation (according to IEC 60746) is based on a fixed nonlinear curve that defines the relationship between the temperature coefficient and the temperature. This curve is used for lower concentrations of up to approx. 5 % NaCl.

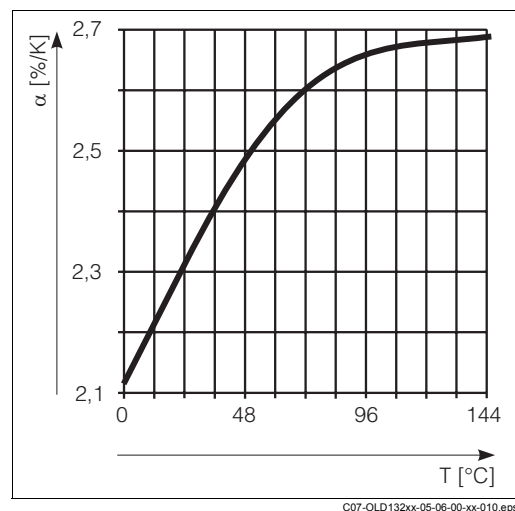

Fig. 23: NaCl compensation

### Ultrapure water compensation (for conductive sensors)

For pure and ultrapure water, algorithms are saved in the transmitter that account for the self-dissociation of ultra pure water and its strong temperature dependency. They are used for conductivities of approx. 100  $\mu\text{S}/\text{cm}$  verwendet.

Two compensation types are available:

- NaCl ultrapure water compensation: It is optimised for pH neutral impurities.
- HCl ultrapure water compensation: It is optimised for measurement of the so-called acid conductivity after a cation exchanger. It is also suitable for ammonia ( $\text{NH}_3$ ) and caustic soda ( $\text{NaOH}$ ).



Note!

- The ultrapure water compensations always refer to a reference temperature of 25 °C / 77 °F.
- The lowest indicated conductivity is the theoretical limit value of ultrapure water at 25 °C / 77 °F, i.e. 0.055  $\mu\text{S}/\text{cm}$ .

### Temperature compensation with table

In case of transmitter with Plus package you can enter a table with temperature coefficients  $\alpha$  in relation to temperature. When using the alpha table function for temperature compensation, the following conductivity data of the process medium to be measured is required:

Value pairs of temperature  $T$  and conductivity  $\kappa$  with:

- $\kappa(T_0)$  for the reference temperature  $T_0$
- $\kappa(T)$  for temperatures which occur in the process

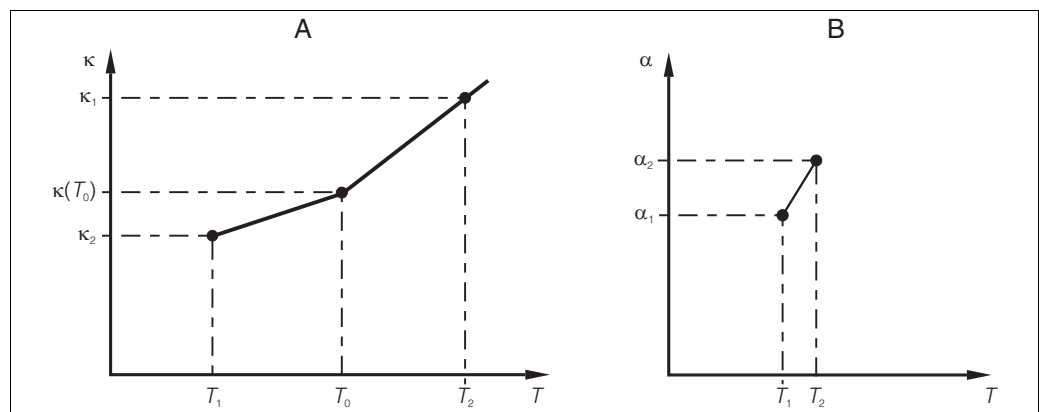

C07-OLM153xx-05-06-00-xx-003.eps

Fig. 24: Determination of temperatur coefficient

- A Required data  
B Calculated  $\alpha$  values

Use the following formula to calculate the  $\alpha$  values for the temperatures occurring in your process:

$$\alpha = \frac{100\%}{\kappa(T_0)} \cdot \frac{\kappa(T) - \kappa(T_0)}{T - T_0}; T \neq T_0$$

Enter the  $\alpha$ - $T$  value pairs calculated with this formula in the fields T4 and T5 of the function group "ALPHA TABLE".

In the SETUP 2 function group, you can change the settings for temperature measurement.  
Basic version does not include functions in *italic*.

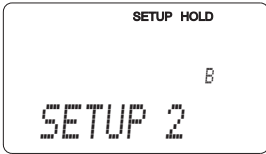
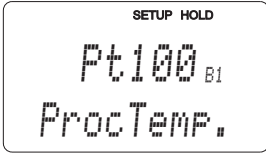
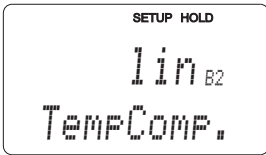
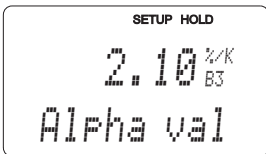
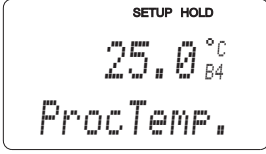
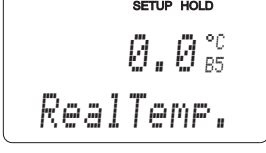
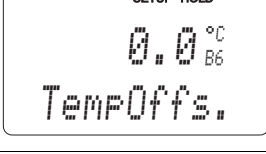
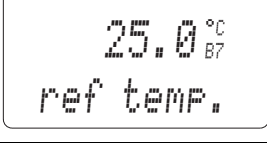
Coding	Field	Selection or range (factory settings bold)	Display	Info
<b>B</b>	<b>Function group SETUP 2</b>			Settings for temperature measurement.
B1	Select temperature sensor	<b>Pt100</b> Pt1k = Pt 1000 NTC30 fixed		If set to "fixed": Manual temperature compensation (MTC), no temperature measurement if fixed temperature value is specified in B4. No temperature output if "fixed"!
B2	Select temperature compensation type	none <b>lin = linear</b> NaCl = common salt (IEC 60746) Pure = ultrapure water NaCl PureH = ultrapure water HCl <i>Tab = table</i>		This option is not displayed for concentration measurement. "Pure" and "PureH" are only available for conductive devices.
B3	Enter temperature coefficient $\alpha$	<b>2.10 %/K</b> 0.00 ... 20.00 %/K		Only if B2 = lin. With other settings in B2, field B3 has no influence.
B4	Enter process temperature	<b>25 °C</b> -35.0 ... 250.0 °C		Only if B1 = fixed. This value can only be specified in °C.
B5	Display temperature and calibrate temperature sensor	Display and entry of real temperature -35.0 ... 250.0 °C		This entry is used to calibrate the temperature sensor to an external measurement. Effects B6. Omitted if B1 = fixed.
B6	Enter temperature difference (offset)	<b>Curent offset</b> -5.0 ... 5.0 °C		The offset is the difference between the entered actual value and the measured temperature. Omitted if B1 = fixed.
B7	Enter reference temperature	<b>25 °C</b> -5.0 ... 100 °C		

### 6.4.3 Current input

To use the "Current input" function group, you need a relay board with current input which is not part of the basic version. With this function group you can monitor process parameters and use these for feedforward control. For this purpose, you must connect the current output of an external measured variable (e.g. flowmeter) to the 4 ... 20 mA input of the transmitter. The following assignment applies:

	Flow in main stream	Current signal in mA	Current input signal in %
Current input lower range limit	Flowmeter lower setting value	4	0
Current input upper range limit	Flowmeter upper setting value	20	100

#### Monitoring of flow in main stream

This arrangement is particularly practical if the sample flow through a flow assembly in an open outlet is completely independent of the flow in the main stream.

This permits signalling of an alarm condition in the main stream (flow too low or has completely stopped) and triggers dosing switch-off even if the medium flow is retained due to the method of installation.

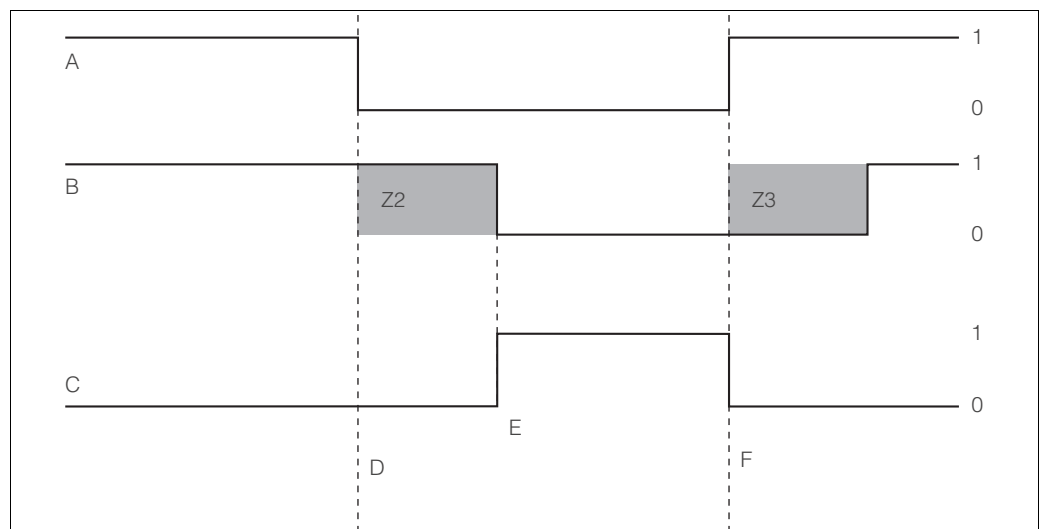

C07-OPM2x3cx-05-06-00-xx-001.eps

Fig. 25: Alarm signalling and dosing switch-off by the main stream

- |   |   |    |   |
|---|---|----|---|
| A | Flow in main stream                             | F  | Flow restoration                              |
| B | Relay contacts of PID controller                | Z2 | Delay for controller switch-off, see field Z2 |
| C | Alarm relay                                     | Z3 | Delay for controller switch-on, see field Z3  |
| D | Flow below switch-off limit Z 4 or flow failure | 0  | Off   |
| E | Flow alarm                                      | 1  | On  |

### Feedforward control to PID controller

For control systems with very short reaction times, you can optimise the control. Additionally you measure the flow rate of the medium. This flow rate value (0/4 ... 20 mA) you apply as feedforward control to the PID controller.

Feedforward control is a multiplying function as illustrated in the figure below (example with factory setting):

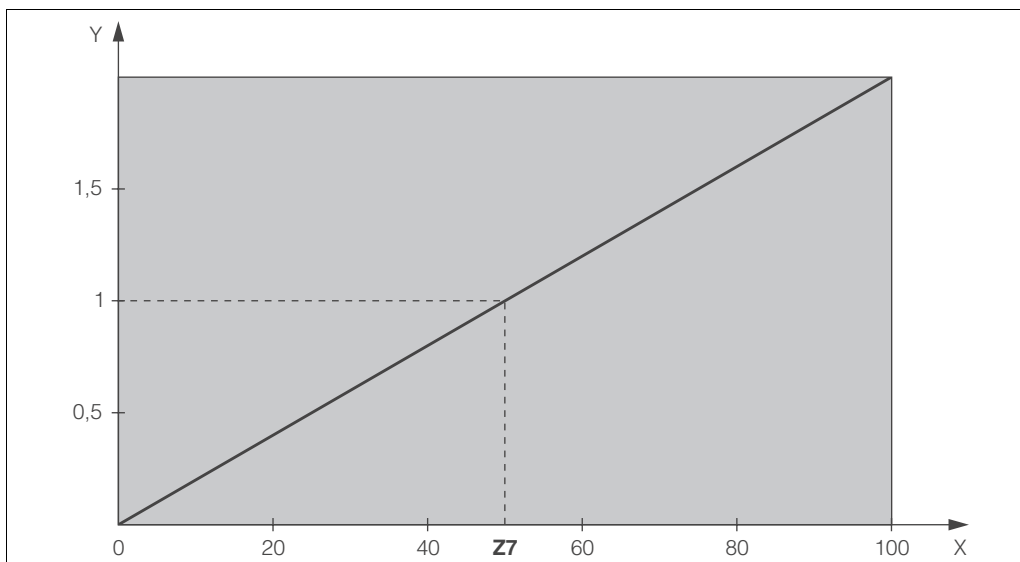

C07-OPM2x3xx-05-06-00-de-003.eps

Fig. 26: Multiplying feedforward control

- Y Gain  $K_{inf}$
- X Current input signal [%]
- Z7 Input value, when gain  $K_{inf} = 1$

Basic version does not include functions in *italic*.

Coding	Field	Setting range (Factory settings, bold)	Display	Info
<b>Z</b>	<b>CURRENT INPUT function group</b>			Current input settings.
Z1	Select flow monitoring of main stream (with controller switch-off)	<b>Off</b> On		Flow monitoring may only be switched on if the flowmeter is connected in the main stream. If Z1 = off, fields Z2 to Z5 are not available.
Z2	Enter the delay for controller switch-off through current input	<b>0 s</b> 0 ... 2000 s		Brief flow shortfalls can be suppressed by a delay and do not result in controller switch-off.
Z3	Enter the delay for controller switch-on through current input	<b>0 s</b> 0 ... 2000 s		In the case of a controller, a delay until a representative measured value is received is useful if the flow fails for an extended period.
Z4	Enter the switch-off limit value for the current input	<b>50%</b> 0 ... 100%		0 ... 100% corresponds to 4 ... 20 mA at the current input. Observe measured value assignment to the current output of the flowmeter.
Z5	Enter the switch-off direction for the current input	<b>Low</b> High		The controller is switched off if the value entered in Z4 is undershot or overshot.
Z6	Select feedforward control to PID controller	<b>Off</b> <i>Lin = linear</i> <i>Basic</i>		If Z6 = off, the field Z7 is not available. Z6 = basic: disturbance variable only affects the basic load (alternatively dosing in proportion to quantity if usual PID controller not possible, e.g. defective sensor).
Z7	Enter value for feedforward control at which gain = 1 applies	<b>50%</b> 0 ... 100%		When the value is set, the controller actuating variable is the same size when feedforward control is switched on as when feedforward control is switched off.

### 6.4.4 Current outputs

Use the "Current output" function group to configure the individual outputs. You can enter either a linear characteristic (O3 (1)) or a user-defined current output characteristic in conjunction with the Plus Package (O3 (3)). Exception: if you have chosen a "continuous controller" for current output 2, you cannot enter a user-defined current output characteristic for this current output.

In addition, you can also simulate a current output value (O3 (2)) to check the current outputs. If a second current output is present, you can output the controller actuating variable in accordance with field R237 / O2 via the current output.

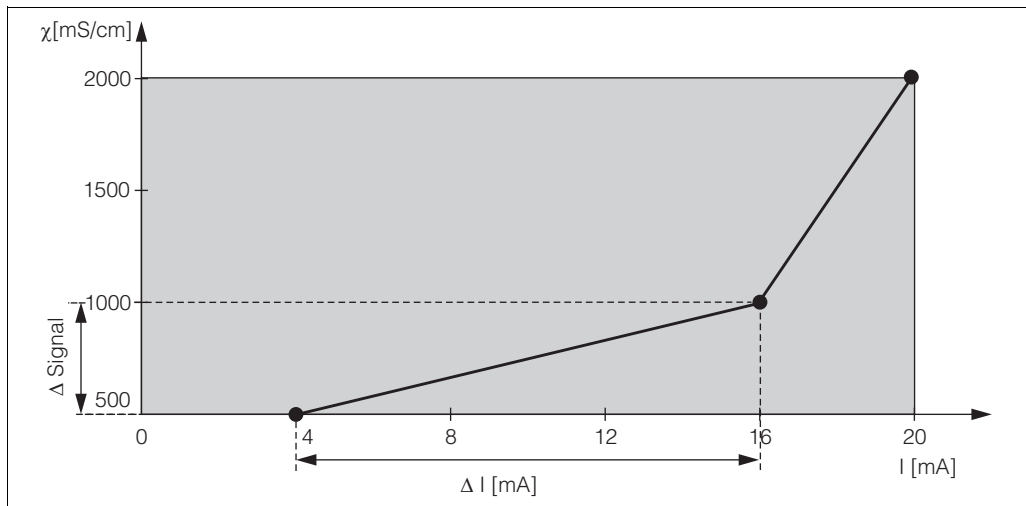

C07-OLM2x3xx-05-06-00-xx-004.eps

Fig. 27: User-defined current output characteristic (example)

The current output characteristic must be strictly monotonously increasing or strictly monotonously decreasing.

The distance per mA between two table value pairs must be greater than:

- Conductivity: 0.5 % of measuring range per mA
- Temperature: 0.25 °C per mA

The values for the sample characteristic (Fig. 27) are entered in the following table. The distance per mA can be calculated from  $\Delta \text{ signal} / \Delta \text{ mA}$ .

Value pair	Current output 1			Current output 2		
	[mS/cm] [%] [°C]	Current [mA]	Distance per mA	[mS/cm] [%] [°C]	Current [mA]	Distance per mA
1	500	4				
2	1000	16	41.66			
3	2000	20	250			

First enter the desired current output configuration into the following blank table with a pencil. Calculate the resulting signal distance per mA to observe the necessary minimum slope. Then enter the values in the device.

Current output 1				Current output 2		
Value pair	[mS/cm] [%] [°C]	Current [mA]	Distance per mA	[mS/cm] [%] [°C]	Current [mA]	Distance per mA
1						
2						
3						
4						
5						
6						
7						
8						
9						

Basic version does not include functions in *italic*.

Coding	Field	Setting range (Factory settings, bold)	Display	Info
<b>O</b>	<b>CURRENT OUTPUT function group</b>			Configuration of the current output (does not apply for PROFIBUS).
	O1	Select current output <b>Out1</b> <i>Out 2</i>		A characteristic can be selected for every output.
	O2	Select measured variable for 2nd current output <b>°C</b> <i>mS/cm, MΩ, %</i> <i>Contr</i>		R237 = curr (current output 2) can only be selected if O2 = Contr is selected (relay board required).
	O3 (1)	Enter or output linear characteristic <b>Lin = linear (1)</b> <i>Sim = simulation (2)</i> <i>Tab = table (3)</i>		The characteristic can have a positive or negative slope for the measured value output. In the case of actuating variable output (O2 = Contr), an increasing current corresponds to an increasing actuating variable.
	O311	Select current range <b>4 ... 20 mA</b> <i>0 ... 20 mA</i>		

Coding		Field	Setting range (Factory settings, bold)	Display	Info
	O312	0/4 mA value: Enter corresponding measured value	cond/ind: <b>0.00</b> $\mu\text{S/cm}$ MOhm: <b>0.00</b> $\text{k}\Omega\text{-cm}$ Conc: <b>0.00</b> % Temp: <b>0.00</b> $^{\circ}\text{C}$		Here you can enter the measured value at which the min. current value (0/4 mA) is applied at the transmitter output. (Spreading: see Technical data.)
	O313	20 mA value: Enter corresponding measured value	cond/ind: <b>2000</b> $\text{mS/cm}$ MOhm: <b>500</b> $\text{k}\Omega\text{-cm}$ Conc: <b>99.99</b> % Temp: <b>150</b> $^{\circ}\text{C}$		Here you can enter the measured value at which the max. current value (20 mA) is applied at the transmitter output. (Spreading: see Technical data.)
	O3 (2)	Simulate current output	Lin = linear (1) <b>Sim = simulation</b> (2) Tab = table (3)		Simulation is not ended until (1) or (3) is selected. For further characteristics, see O3 (1), O3(3).
	O321	Enter simulation value	<b>Current value</b> 0.00 ... 22.00 mA		Entering a current value results in this value being directly output at the current output.
	O3 (3)	<i>Enter current output table (only for Plus Package)</i>	Lin = linear (1) Sim = simulation (2) Tab = table (3)		Values can also be added or altered at a later stage. The values entered are automatically sorted by increasing current value. For further characteristics, see O3 (1), O3 (2).
	O331	Select table options	<b>Read</b> Edit		
	O332	Enter number of table value pairs	<b>1</b> 1 ... 10		Enter the number of pairs from the x and y value (measured value and current value) here.
	O333	Select table value pair	<b>1</b> 1 ... No. elem. Assign		The function chain O333 ... O335 will run through as many times as correspond to the value in O332. "Assign" appears as the last step. After confirmation the system jumps to O336.
	O334	Enter x value	cond/ind: <b>0.00</b> $\mu\text{S/cm}$ MOhm: <b>0.00</b> $\text{k}\Omega\text{-cm}$ Conc: <b>0.00</b> % Temp: <b>0.00</b> $^{\circ}\text{C}$		x value = measured value specified by user.

Coding		Field	Setting range (Factory settings, bold)	Display	Info
	O335	Enter y value	<b>4.00 mA</b> 0.00 ... 20.00 mA		y value = current value belonging to O334 specified by user. Return to O333 until all values are entered.
	O336	Message as to whether table status is OK	<b>yes</b> no		Back to O3. If status = no, correct table (all settings made up until now are retained) or back to measuring mode (table is deleted).

### 6.4.5 Alarm

In the ALARM function group, you can define various alarms and configure output contacts. Each individual error can be defined to be effective or not (at the contact or as an error current).

Coding		Field	Setting range (Factory settings, bold)	Display	Info
F		<b>ALARM function group</b>			Alarm function settings.
	F1	Select contact type	<b>Latch = latching contact</b> Momen = momentary contact		The contact type selected only applies to the alarm contact.
	F2	Select time unit	<b>s</b> min		
	F3	Enter alarm delay	<b>0 s (min)</b> 0 ... 2000 s (min)		Depending on the option selected in F2, the alarm delay is entered in s or min.
	F4	Select error current	<b>22 mA</b> 2.4 mA		This selection must be made even if all error reporting is switched off in F5. <b>Caution!</b> If "0-20 mA" was selected in O311, "2.4 mA" may not be used.
	F5	Select error	<b>1</b> 1 ... 255		Here you can select all the errors which should trigger an alarm. The errors are selected via the error numbers. Please refer to the table in section "System error messages" for the meaning of the individual error numbers. The factory settings remain in effect for all errors not edited.

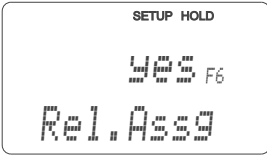
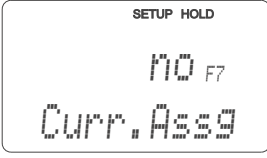
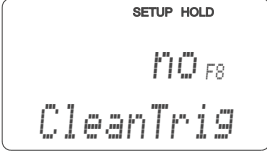
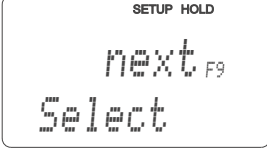
Coding		Field	Setting range (Factory settings, bold)	Display	Info
	F6	Set alarm contact to be effective for the selected error	<b>yes</b> no		If "no" is selected, all the other alarm settings are deactivated (e.g. alarm delay). The settings themselves are retained. This setting <b>only</b> applies to the error selected in F5.
	F7	Set error current to be effective for the selected error	<b>no</b> yes		The option selected in F4 is effective or ineffective in the event of an error. This setting <b>only</b> applies to the error selected in F5.
	F8	<i>Automatic cleaning function start</i>	<b>no</b> yes		This field is not available for certain errors, see "Trouble-shooting and fault elimination" section.
	F9	Select return to menu or next error	<b>next</b> = next error ←R		If ←R is selected, you return to F, if next is selected, you go to F5.

### 6.4.6 Check

The CHECK function group is only available for devices with a Plus Package. In the CHECK function group, you can select different monitoring functions for the measurement:

#### Polarisation detection (field P1)

Polarisation effects in the interface between sensor and measuring solution limit the measuring range of conductive conductivity sensors. The transmitter has the ability to detect polarisation effects using an intelligent evaluation process. Error code E071 will be generated.

#### Alarm threshold monitoring (fields P2 to P5)

You can use this function to monitor the measured value for permissible upper and lower limits and trigger an alarm (E154, E155).

#### PCS alarm (Process Check System), (fields P6 to P9)

**AC (Alternating Check):** The function AC (field P6) is used to check measuring signals for deviations. If the measuring signal change within an hour is smaller than 0.5% (of full scale value of the selected measuring range), an alarm (E152) is triggered. The reason for such sensor behaviour can be contamination, cable rupture or similar.

**CC (Controller Check):** You can monitor the controller activity with the function CC. This function is mainly used for batch processes and single-sided limit switches. A malfunction of the controller is detected and reported thanks to freely adjustable monitoring times (E156 -E157).

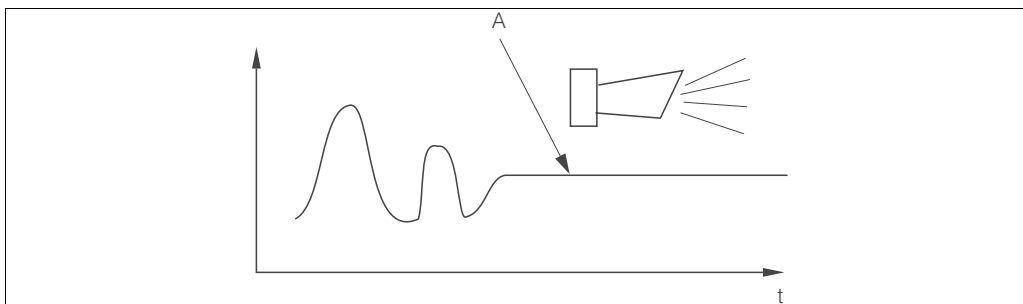

C07-OxM2x3xx-05-06-00-xx-001.eps

Fig. 28: PCS alarm (live check)

A Constant measuring signal = alarm triggered after PCS alarm time has elapsed



**Note!**  
Any PCS alarm pending is automatically deleted as soon as the sensor signal changes.  
Basic version does not include functions in *italic*.

Coding	Field	Setting range (Factory settings, bold)	Display	Info
P	<b>CHECK function group</b>			Settings for sensor and process monitoring
P1	<i>Switch polarisation detection on or off (conductive only)</i>	<b>Off</b> On		Polarisation only occurs with conductive sensors. Polarisation is detected, but not compensated. (error no.: E071)
P2	<i>Set PCS Alarm (live check)</i>	<b>Off</b> Low High Lo+Hi Low! High! Lo+Hi!		Alarm signalling optionally with or without simultaneous controller switch-off. XXXX = without controller switch-off XXXX! = with controller switch-off (error no.: E154, E155)
P3	<i>Enter error delay</i>	<b>0 s (min)</b> 0 ... 2000 s (min)		Depending on your selection in F2, you can enter the error delay in min or s. Only after this delay does a high or low limit violation cause an alarm as per field P4/P5.
P4	<i>Enter lower alarm threshold</i>	<b>0 μS/cm</b> 0 ... 9999mS/cm		
P5	<i>Enter upper alarm threshold</i>	<b>9999 μS/cm</b> 0 ... 9999mS/cm		

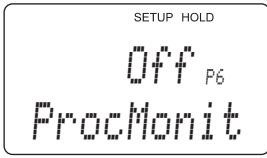
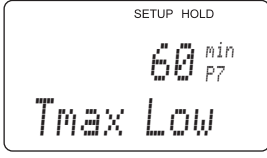
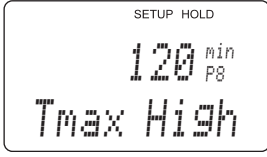
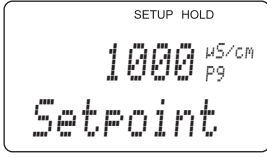
Coding		Field	Setting range (Factory settings, bold)	Display	Info
	P6	Select process monitoring (PCS alarm)	<b>Off</b> AC CC AC+CC AC! CC! AC+CC!		AC = sensor alternation check (E152) CC = controller check (E156, E157) Alarm signalling optionally with or without simultaneous controller switch-off. XXXX = without controller switch-off XXXX! = with controller switch-off
	P7	Enter maximum permissible duration for lower CC setpoint limit violation (field P9)	<b>60 min</b> 0 ... 2000 min		Only when P6 = CC or AC+CC
	P8	Enter maximum permissible duration for upper CC setpoint limit violation (field P9)	<b>120 min</b> 0 ... 2000 min		Only when P6 = CC or AC+CC
	P9	Enter CC setpoint (for P7/P8)	<b>1000 µS/cm</b> 0 ... 9999 mS/cm		Selected value is an absolute value. This function is mainly used for batch processes and single-sided limit switches.

### 6.4.7 Relay contact configuration

To use the RELAY function group you need a relay board which is not part of the basic version.

The following relay contacts can be selected and configured as desired (max. four contacts, depending on options installed):

- Limit contactor for measured conductivity value: R2 (1)
- Limit contactor for temperature: R2 (2)
- PID controller: R2 (3)
- Timer for cleaning function: R2 (4)
- Chemoclean function: R2 (5)
- USP/EP: R2 (6) and R2 (7) (for Plus Package, conductive only)

#### Limit contactor for measured conductivity value and temperature

The transmitter has different ways of assigning a relay contact.

Switch-on and switch-off points and pick-up and drop-out delays can be assigned to the limit contactor. In addition, you can configure an alarm threshold to output an error message and to start a cleaning function in conjunction with this.

These functions can be used both for conductivity measurement and for temperature measurement.

Please refer to Fig. 29 for a clear illustration of the relay contact states.

- When the measured values increase (maximum function), the relay contact is closed as of  $t_2$  after the switch-on point ( $t_1$ ) has been overshoot and the pick-up delay has elapsed ( $t_2 - t_1$ ). The alarm contact switches if the alarm threshold ( $t_3$ ) is reached and the alarm delay ( $t_4 - t_3$ ) (field F3) has also elapsed (error E067 to E070).
- When the measured values decrease, the alarm contact is reset when the alarm threshold ( $t_5$ ) is undershot as is the relay contact ( $t_7$ ) after the drop-out delay ( $t_7 - t_6$ ).
- If the pick-up and drop-out delays are set to 0 s, the switch-on and switch-off points are also switch points of the contacts.

Settings can also be made for a minimum function in the same way as for a maximum function.

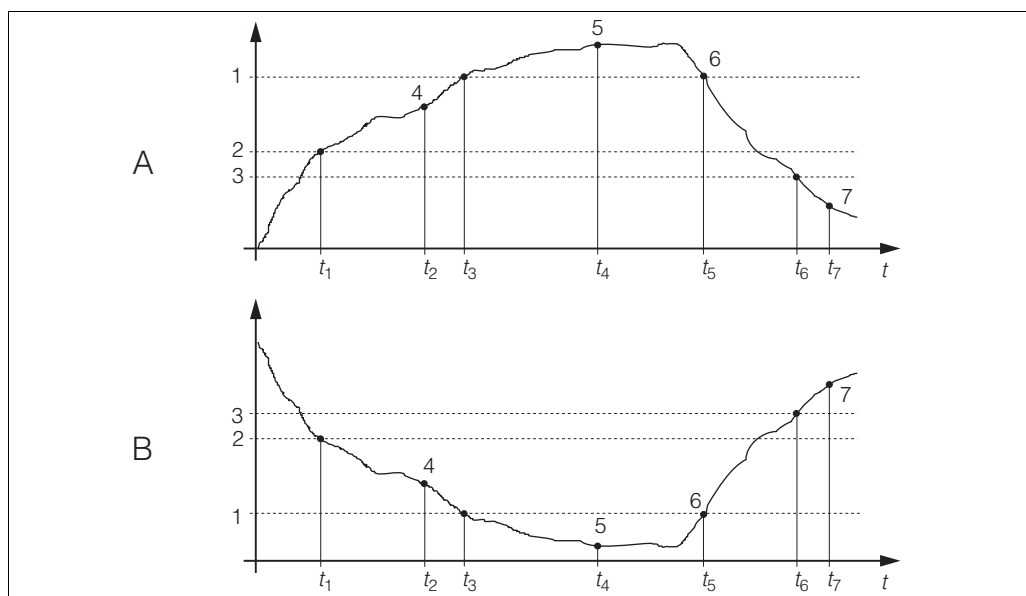

C07-OxM2x3xx-05-06-00-xx-003.eps

Fig. 29: Illustration of the alarm and limit value functions

A	Switch-on point > switch-off point: Max. function	1	Alarm threshold	5	Alarm ON
B	Switch-on point < switch-off point: Min. function	2	Switch-on point	6	Alarm OFF
		3	Switch-off point	7	Contact OFF
		4	Contact ON		

### P(ID) controller

You can define various controller functions for the transmitter. On the basis of the PID controller, P, PI, PD and PID controllers can be implemented. For an optimum control system, use the controller that best suits your application. Depending on the option selected in the R 237 / R 266 field, the actuating signal can be output via relays or via current output 2 (if available).

- **P controller**

Used for simple linear control purposes with small system deviations. Where major changes are to be controlled, overshooting may occur. In addition, a lasting control deviation is to be expected.

- **PI controller**

Is used for control systems where overshooting is to be avoided and no lasting control deviation should occur.

- **PD controller**

Is used for processes that require quick changes and where peaks are to be corrected.

- **PID controller**

Is used for processes where a P, PI or PD controller does not control sufficiently.

### Configuration options of the PID controller

The following configuration options are available for a PID controller:

- Change control gain  $K_p$  (P influence)
- Set integral action time  $T_n$  (I influence)
- Set derivative action time  $T_v$  (D influence)

### Basic load dosing (Basic)

The basic load dosing (field R231) is used to set a constant dosage (field R2311)

### PID controlling plus basic load dosing

If you select this function (PID + Basic) in field R231 the PID controlled dosage will not be lower than the basic load value entered in field R2311.

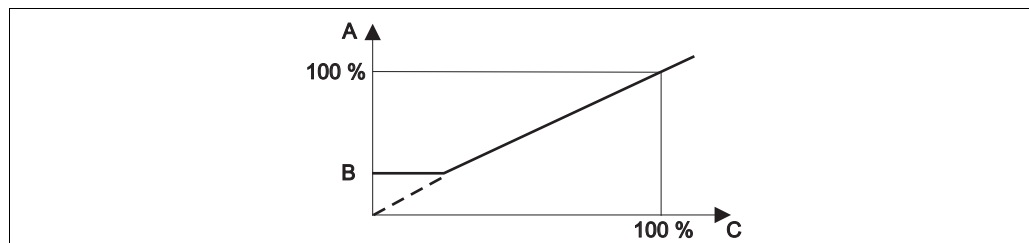

C07-OxM2x3xx-05-06-00-xx-010.eps

Fig. 30: Control characteristic PID controller with basic load dosing

- A PID with basic load
- B Basic load
- C PID

### Commissioning

If you do not yet have any experience for setting the control parameters, set the values that yield the greatest possible stability in the control circuit. Proceed as follows to optimise the control circuit further:

- Increase the control gain  $K_p$  until the controlled variable just starts to overshoot.
- Reduce  $K_p$  slightly and then reduce the integral action time  $T_n$  so that the shortest possible correction time without overshooting is achieved.
- To reduce the response time of the controller, also set the derivative action time  $T_v$ .

**Control and fine optimisation of the set parameters with a recorder**

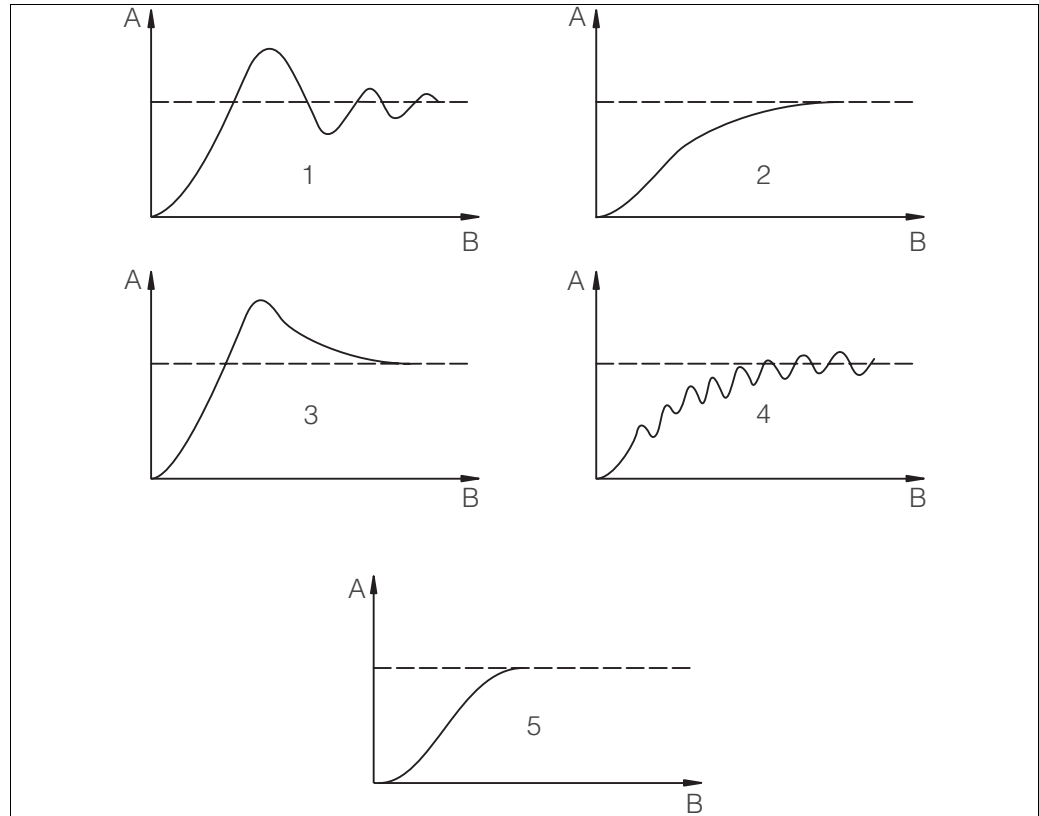

C07-OLM2x3xx-05-06-00-xx-004.eps

Fig. 31: Optimisation of settings  $T_n$  and  $K_p$

A Actual value  
B Time

- |                   |                   |
|-------------------|-------------------|
| 1 $T_n$ too small | 4 $K_p$ too small |
| 2 $T_n$ too large | 5 Optimum setting |
| 3 $K_p$ too large |                   |

**Actuating signal outputs (R237 ... R2310)**

Each control contact outputs a cyclical signal whose intensity corresponds to the controller's manipulated variable. A distinction is made according to the type of signal cycle:

- Pulse length modulation  
The bigger the calculated manipulated variable is, the longer the contact affected remains picked up. The period  $T$  can be adjusted between 0.5 and 99 s (field R238). Outputs with pulse length modulation are used to activate solenoid valves.
- Pulse frequency modulation  
The bigger the calculated manipulated variable is, the higher the switching frequency of the contact affected. The maximum switching frequency  $1/T$  can be set between 60 and 180  $\text{min}^{-1}$ . The on-time  $t_{\text{ON}}$  is constant. It depends on the set maximum frequency and is approx. 0.5 s for 60  $\text{min}^{-1}$  and approx. 170 ms for 180  $\text{min}^{-1}$ . Outputs with pulse frequency modulation are used to activate directly controlled solenoid dosing pumps.

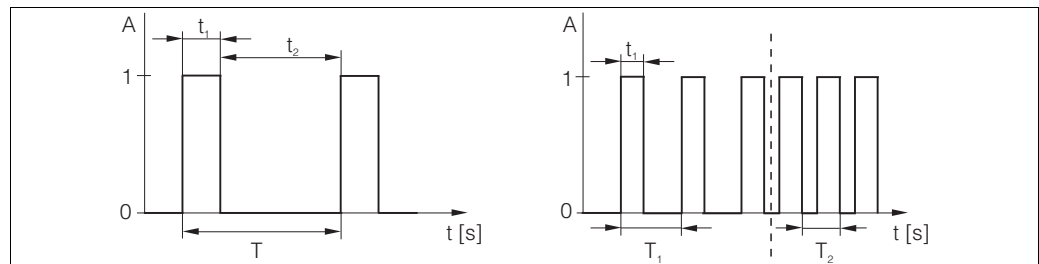

C07-OLM2x3xx-05-06-00-xx-005.eps

Fig. 32: Signal of a pulse-length modulated controller contact (left) and of a pulse-frequency modulated controller contact (right)

A Contact 1 = on, 0 = off  
B Time [s]  $t_1 = t_{\text{on}}$   $t_2 = t_{\text{off}}$

$T$  Period length  
 $T_1$   $T_2$  Impulse period length (impulse freq.  $1/T_1$  and  $1/T_2$ )

**Constant controller**

Via the current output 2, the minimum actuating variable (0 %) of the controller is output with 0/4 mA and the maximum actuating variable (100%) of the controller is output with 20 mA.

**Control characteristic for direct and inverse control action**

You can choose between two control characteristics in the R236 field:

- Direct control action = maximum function
- Inverse control action = minimum function

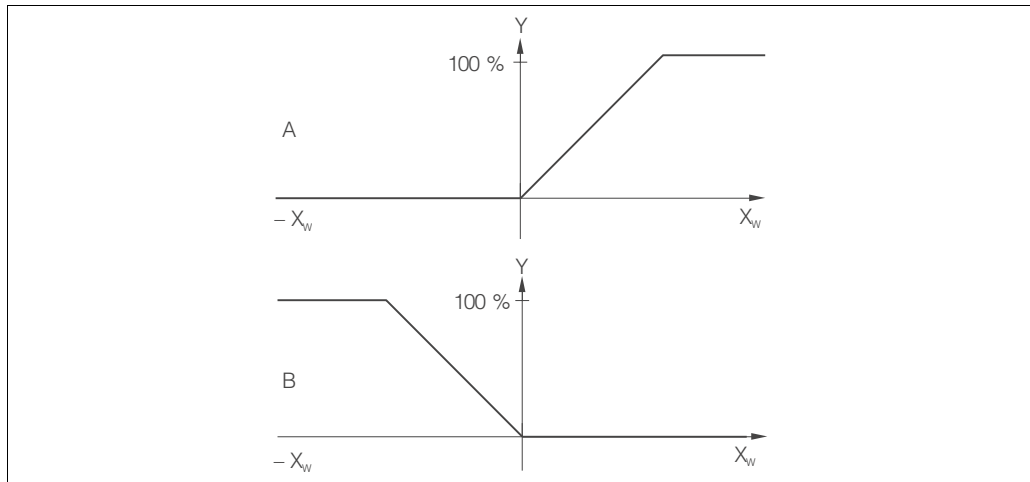

C07-OxM2x3xx-05-06-00-xx-006.eps

Fig. 33: Control characteristic of a proportional controller with direct and inverse control action

- A Direct = max. function
- B Inverse = min. function

**Timer for cleaning function**

This function includes a simple cleaning option. You can set the time interval after which cleaning should start. So you can only select a constant interval sequence.

Other cleaning functions are available for selection in conjunction with the Chemoclean function (version with four contacts, see "Chemoclean function" section).



**Note!**

Timer and Chemoclean do not work independently of one another. While one of the two functions is active, the other cannot be started.

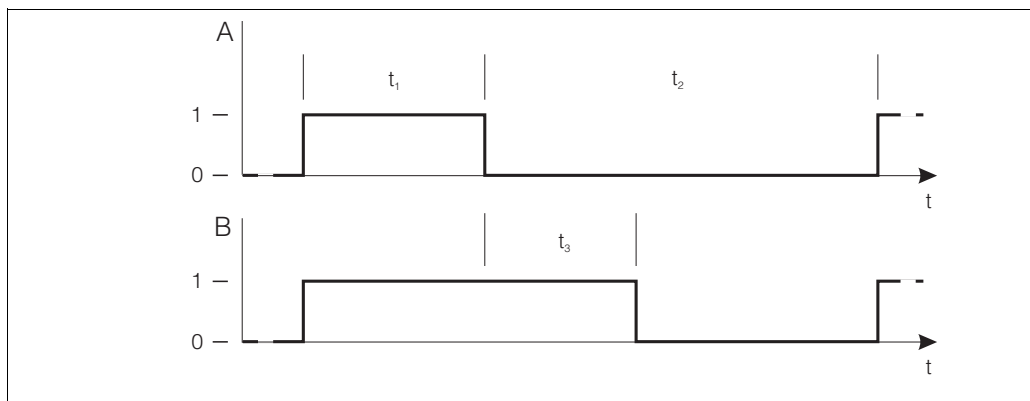

C07-OLM2x3xx-05-06-xx-007.eps

Fig. 34: Connection between cleaning time, pause time and Hold dwell period

- |   |                                    |                |  |
|---|------------------------------------|----------------|--|
| A | Wiper and/or spray cleaning system | t <sub>1</sub> | Cleaning time (0 ... 999 s)                                |
| B | Hold function                      | t <sub>2</sub> | Pause time between two cleaning intervals (1 ... 7200 min) |
| 0 | Inactive                           | t <sub>3</sub> | Clean Hold dwell period (0 ... 999 s)                      |
| 1 | Active                             |                |  |

### Chemoclean function

Just like the timer function, Chemoclean can also be used to start a cleaning cycle. However, Chemoclean also gives you the added option of defining different cleaning and rinsing intervals.

As a result, it is possible to clean irregularly with different repeat cycles and to separately set the cleaning times with post rinse times.



#### Note!

- To use the Chemoclean function the transmitter has to be equipped with a designated relay board (see product structure or chapter "accessories").
- Timer and Chemoclean do not work independently of one another. While one of the two functions is active, the other cannot be started.
- For the Chemoclean function, the relays 3 (water) and 4 (cleaner) are used.
- If the cleaning is prematurely aborted, a post rinse time always follows.
- If the setting is "Economy", cleaning only takes place with water.

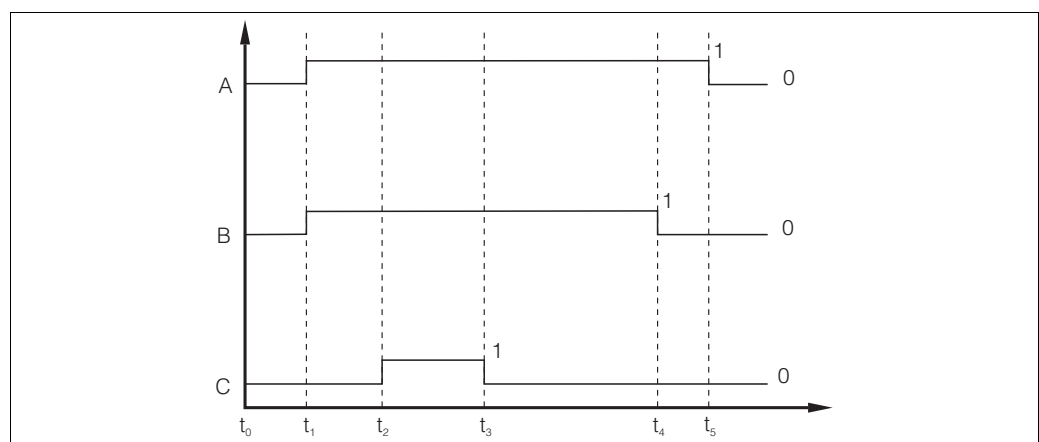

C07-OxM2x3xx-05-06-00-xx-008.eps

Fig. 35: Sequence of a cleaning cycle

A Hold  
B Water  
C Cleaner

$t_1$  Cleaning start  
 $t_2 - t_1$  Pre-rinse time  
 $t_3 - t_2$  Cleaning time  
 $t_4 - t_3$  Post rinse time  
 $t_5 - t_4$  Hold dwell period

### Limit values for pharmaceutical water according to United States Pharmacopeia (USP) and European Pharmacopoeia (EP) (conductive only)

The transmitter (conductive sensors only) can monitor "Water for Injection" (WFI), "Highly Purified Water" (HPW) and "Purified Water" (PW) according to the standard United States Pharmacopeia (USP) part 645 and European Pharmacopoeia (EP).

**USP function:** For "Water for Injection" (WFI) according to the standard of USP and EP and for "Highly Purified Water" (HPW) according to the standard of EP the transmitter uses the temperature depending limit values of the following table:

Temperature [°C/°F]	Conductivity [ $\mu\text{S}/\text{cm}$ ]	Temperature [°C/°F]	Conductivity [ $\mu\text{S}/\text{cm}$ ]
0/32	0.6	55/131	2.1
5/41	0.8	60/140	2.2
10/50	0.9	65/149	2.4
15/59	1.0	70/158	2.5
20/68	1.1	75/167	2.7
25/77	1.3	80/176	2.7
30/86	1.4	85/185	2.7
35/95	1.5	90/194	2.7
40/104	1.7	95/203	2.9
45/113	1.8	100/212	3.1
50/122	1.9		

The measurement is performed as follows:

- The transmitter determines the uncompensated conductivity and the water temperature .
- The transmitter rounds off the temperature to the next 5 °C step and compares the actual measured conductivity with the value of the table.
- If the measured value exceeds the table value an alarm (E151) will be triggered.

**EP-PW function:** For "Purified Water" (PW) according to the standard of EP the transmitter uses the temperature depending limit values of the following table:

Temperature [°C/°F]	Conductivity [ $\mu\text{S}/\text{cm}$ ]	Temperature [°C/°F]	Conductivity [ $\mu\text{S}/\text{cm}$ ]
0/32	2.4	60/140	8.1
10/50	3.6	70/158	9.1
20/68	4.3	75/167	9.7
25/77	5.1	80/176	9.7
30/86	5.4	90/194	9.7
40/104	6.5	100/212	10.2
50/122	7.1		

The measurement is performed as follows:

- The transmitter determines the uncompensated conductivity and the water temperature .
- The transmitter determines the conductivity limit value by interpolation of two table values.
- If the measured value exceeds the table value an alarm (E151) will be triggered.

**Prealarm:** Also available is a pre-alarm with a user defined switch-on point (e.g. 80 % of the USP/EP value). This gives the user a signal for the in-time regeneration of the system. Enter the value in field R262 or R272.



## Note!

- To use the USP and EP functions the transmitter has to be equipped with a relay board and the Plus Package.
- For alarm output, activate the fault-signalling contact or the error current in field F5 - F7 (error code E151 and E153).
- The switch-off point of the pre-alarm is 1 % below of the switch-on point (R262 / R272), related to the main limit value.
- The transmitter uses uncompensated values for the USP and EP functions even in case temperature compensated values are displayed.
- At temperatures above 100 °C (212 °F) the transmitter uses the limit value of 100 °C (212 °F).

Basic version does not include functions in *italic*.

Coding	Field	Setting range (Factory settings, bold)	Display	Info
R	<b>RELAY function group</b>			Relay contact settings.
R1	Select contact to be configured	<b>Rel1</b> <i>Rel2</i> <i>Rel3</i> <i>Rel4</i>		Rel3 (water) and Rel4 (cleaner) are only available with the relevant version of the transmitter. If Chemoclean is used as the cleaning method, Rel4 is not available.
R2 (1)	Configuration limit contactor for conductivity, resistivity or concentration measurement	<b>LC PV = limit contactor cond (1)</b> LC °C = limit contactor T (2) PID controller (3) Timer (4) <i>Clean = Chemoclean (5)</i> <i>USP (6)</i> <i>EP PW (7)</i>		PV = process value If Rel4 is selected in the R1 field, Clean = Chemoclean cannot be selected. By confirming with ENTER, another relay function already switched on is switched off and its settings are reset to the factory settings.
R211	Switch function of R2 (1) off or on	<b>Off</b> On		All the settings are retained.
R212	Enter the switch-on point of the contact	cond/ind: <b>9999 mS/cm</b> MOhm: <b>200 MΩ.cm</b> conc: <b>9999 %</b>		Never set the switch-on point and the switch-off point to the same value! (Only the operating mode selected in A1 is displayed.)
R213	Enter the switch-off point of the contact	cond/ind: <b>9999 mS/cm</b> MOhm: <b>200 MΩ.cm</b> conc: <b>9999 %</b>		Entering a switch-off point selects either a Max contact (switch-off point < switch-on point) or a Min contact (switch-off point > switch-on point), thereby implementing a hysteresis that is constantly required (see "Illustration of the alarm and limit functions" figure).
R214	Enter pick-up delay	<b>0 s</b> 0 ... 2000 s		

Coding		Field	Setting range (Factory settings, bold)	Display	Info
	R215	Enter drop-out delay	<b>0 s</b> 0 ... 2000 s		
	R216	Enter alarm threshold	cond/ind: <b>9999 mS/cm</b> MOhm: <b>200 MΩ·cm</b> conc: <b>9999 %</b>		If the alarm threshold is undershot/overshot, this triggers an alarm with the error message (E067 to E070) and error current at the transmitter (note alarm delay in field F3). If defined as a Min contact, the alarm threshold must be < switch-off point.
	R217	Display status for limit contactor	<b>MAX</b> MIN		Display only.
R2 (2)		Configure limit contactor for temperature measurement	LC PV = limit contactor cond (1) <b>LC °C = limit contactor T (2)</b> PID controller (3) Timer (4) <i>Clean = Chemoclean (5)</i> <i>USP (6)</i> <i>EP PW (7)</i>		By confirming with ENTER, another relay function already switched on is switched off and its settings are reset to the factory settings.
	R221	Switch function of R2 (2) off or on	<b>Off</b> On		
	R222	Enter switch-on temperature	<b>250.0 C</b> -35.0 ... 250.0 C		Never set the switch-on point and the switch-off point to the same value!
	R223	Enter switch-off temperature	<b>250.0 C</b> -35.0 ... 250.0 C		Entering a switch-off point selects either a Max contact (switch-off point < switch-on point) or a Min contact (switch-off point > switch-on point), thereby implementing a hysteresis that is constantly required (see "Illustration of the alarm and limit functions" figure).
	R224	Enter pick-up delay	<b>0 s</b> 0 ... 2000 s		
	R225	Enter drop-out delay	<b>0 s</b> 0 ... 2000 s		

Coding		Field	Setting range (Factory settings, bold)	Display	Info
	R226	Enter alarm threshold (as absolute value)	<b>250.0 C</b> -35.0 ... 250.0 C		If the alarm threshold is undershot/overshot, this triggers an alarm with the error message (E067 to E070) and error current at the transmitter (note alarm delay in field F3). If defined as a Min contact, the alarm threshold must be < switch-off point.
	R227	Display status for limit contactor	<b>MAX</b> MIN		Display only.
R2 (3)		Configure P(ID) controller	LC PV = limit contactor cond (1) LC °C = limit contactor T (2) <b>PID controller (3)</b> Timer (4) <i>Clean = Chemoclean (5)</i> <i>USP (6)</i> <i>EP PW (7)</i>		By confirming with ENTER, another relay function already switched on is switched off and its settings are reset to the factory settings.
	R231	Switch function of R2 (3) off or on	<b>Off</b> On Basic PID+B		On = PID controller Basic = basic load dosing PID+B = PID controller + basic load dosing
	R232	Enter set point	cond/ind: <b>0.00 mS/cm</b> MOhm: <b>0.00 kΩ·cm</b> conc: <b>0.00 %</b>		The set point is the value to be maintained by the control system. Using this control process, this value is restored upwards or downwards when a deviation occurs.
	R233	Enter control gain $K_p$	<b>1.00</b> 0.01 ... 20.00		See "P(ID) controller" section.
	R234	Enter integral action time $T_n$ (0.0 = no I-component)	<b>0.0 min</b> 0.0 ... 999.9 min		See "P(ID) controller" section. With every Hold, the I-component is set to zero. Although Hold can be deactivated in field S2, this does not apply for Chemoclean and timer!
	R235	Enter derivative action time $T_v$ (0.0 = no D-component)	<b>0.0 min</b> 0.0 ... 999.9 min		See "P(ID) controller" section.
	R236	Select controller characteristic	<b>dir = direct</b> inv = inverse		The setting is required depending on the control deviation (upward or downward deviation, see "P(ID) controller" section).

Coding		Field	Setting range (Factory settings, bold)	Display	Info
	R237	Select pulse length or pulse frequency	<b>len = pulse length</b> freq = pulse frequency curr = current output 2		Pulse length e.g. for solenoid valve, pulse frequency e.g. for solenoid dosing pump, see "Actuating signal outputs" section. Curr = current output 2 can only be selected if O2 = Contr.
	R238	Enter pulse interval	<b>10.0 s</b> 0.5 ... 999.9 s		This field only appears if pulse length is selected in R237. If pulse frequency is selected, R238 is skipped and entries continue with R239.
	R239	Enter maximum pulse frequency of the adjuster	<b>120 min<sup>-1</sup></b> 60 ... 180 min <sup>-1</sup>		This field only appears if pulse frequency is selected in R237. If pulse length is selected, R239 is skipped and entries continue with R2310.
	R2310	Enter minimum switch-on time t <sub>ON</sub>	<b>0.3 s</b> 0.1 ... 5.0 s		This field only appears if pulse length is selected in R237.
	R2311	Enter basic load	<b>0 %</b> 0 ... 40 %		When you select the basic load, you enter the desired dosing quantity. 100% basic load would correspond to: – Constantly on for R237 = len – Fmax at R237 = freq (field R239) – 20 mA at R237 = curr
R2 (4)		Configure cleaning function (timer)	LC PV = limit contactor cond (1) LC °C = limit contactor T (2) PID controller (3) <b>Timer (4)</b> Clean = Chemoclean (5) USP (6) EP PW (7)		Cleaning only takes place with one cleaning agent (usually water); see Fig. 41). By confirming with ENTER, another relay function already switched on is switched off and its settings are reset to the factory settings.
	R241	Switch function of R2 (4) off or on	<b>Off</b> On		
	R242	Enter rinsing/cleaning time	<b>30 s</b> 0 ... 999 s		Settings for Hold and relay are active for this time.
	R243	Enter pause time	<b>360 min</b> 1 ... 7200 min		The pause time is the time between two cleaning cycles (see "Timer for cleaning function" section).

Coding		Field	Setting range (Factory settings, bold)	Display	Info
	R244	Enter minimum pause time	<b>120 min</b> 1 ... R243 min		The minimum pause time prevents constant cleaning if a cleaning trigger is present.
R2 (5)		Configure cleaning with Chemoclean (for version with four contacts, Chemoclean option and contacts 3 and 4 assigned)	<i>LC PV = limit contactor cond (1)</i> <i>LC °C = limit contactor T (2)</i> <i>PID controller (3)</i> <i>Timer (4)</i> <b>Clean = Chemoclean (5)</b> <i>USP (6)</i> <i>EP PW (7)</i>		See "Chemoclean function" section. By confirming with ENTER, another relay function already switched on is switched off and its settings are reset to the factory settings.
	R251	Switch function of R2 (5) off or on	<b>Off</b> On		
	R252	Select type of start pulse	<b>Int = internal (time-controlled)</b> <i>Ext = external (digital input 2)</i> <i>I+ext = internal + external</i> <i>I+stp = internal, suppressed by external</i>		The cycle for the "int" function is started by the end of the pause time (R257). No real time clock is available. External suppression is required for irregular time intervals (e.g. weekends).
	R253	Enter pre-rinse time	<b>20 s</b> 0 ... 999 s		Rinsing with water takes place.
	R254	Enter cleaning time	<b>10 s</b> 0 ... 999 s		Cleaning with cleaning agent and water takes place.
	R255	Enter post rinse time	<b>20 s</b> 0 ... 999 s		Rinsing with water takes place.
	R256	Enter number of repeat cycles	<b>0</b> 0 ... 5		R253 ... R255 is repeated.
	R257	Enter pause time	<b>360 min</b> 1 ... 7200 min		The pause time is the time between two cleaning cycles (see "Timer function" section).

Coding		Field	Setting range (Factory settings, bold)	Display	Info
	R258	Enter minimum pause time	<b>120 min</b> 1 ... R257 min		The minimum pause time prevents constant cleaning if an external cleaning start is present.
	R259	Enter number of cleaning cycles without cleaning agent (economy function)	<b>0</b> 0 ... 9		After cleaning with cleaner, up to 9 cleaning sessions can be carried out with water only until the next cleaning session with cleaner takes place.
R2 (6)		Configure USP contact	LC PV = limit contactor cond (1) LC °C = limit contactor T (2) PID controller (3) Timer (4) Clean = Chemoclean (5) <b>USP (6)</b> EP PW (7)		The USP contact can be configured as a pre-alarm, i.e., it issues an alarm before the limit is reached. When an alarm is output, the error no. E151 is displayed. By confirming with ENTER, another relay function already switched on is switched off and its settings are reset to the factory settings. WFI acc. to USP and EP; HPW acc. to EP
	R261	Switch function of R2 (6) off or on	<b>Off</b> On		
	R262	Pre-alarm threshold: Enter switch-on point	<b>80 %</b> 0.0 ... 100.0 %		The pre-alarm effects a contact query. Should the alarm value be reached (100 %) the alarm relay also responds. Example: At 15 °C and 1.0 µS/cm with the setting 80.0 % an USP-pre-alarm is also triggered at 0.8 µS/cm.
	R264	Pre-alarm threshold: Enter pick-up delay	<b>0 s</b> 0 ... 2000 s		
	R265	Pre-alarm threshold: Enter drop-out delay	<b>0 s</b> 0 ... 2000 s		
	R2 (7)		Configure EP PW contact	LC PV = limit contactor cond (1) LC °C = limit contactor T (2) PID controller (3) Timer (4) Clean = Chemoclean (5) USP (6) <b>EP PW (7)</b>	

Coding		Field	Setting range (Factory settings, bold)	Display	Info
	R271	Switch function of R2 (7) off or on	<b>Off</b> On		
	R272	Pre-alarm threshold: Enter switch-on point	<b>80 %</b> 0.0 ... 100.0 %		The pre-alarm effects a contact query. Should the alarm value be reached (100 %) the alarm relay also responds. Example: At 15 °C and 1.0 µS/cm with the setting 80.0 % an EP PW-pre-alarm is also triggered at 0.8 µS/cm.
	R274	Pre-alarm threshold: Enter pick-up delay	<b>0 s</b> 0 ... 2000 s		
	R275	Pre-alarm threshold: Enter drop-out delay	<b>0 s</b> 0 ... 2000 s		

### 6.4.8 Temperature compensation with table

You need the Plus Package to use the function group "ALPHA TABLE". This function group is used to perform a temperature compensation with table (field B2).

Enter the  $\alpha$ -T value pairs in the fields T4 and T5.

Basic version does not include functions in *italic*.

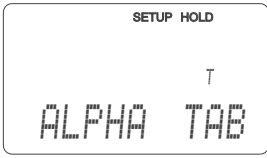
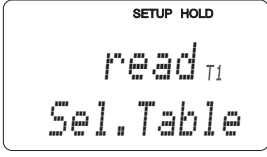
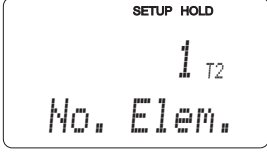
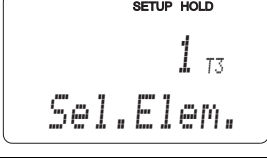
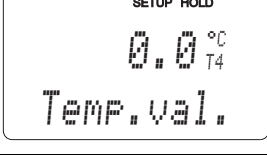
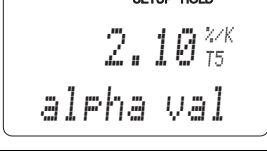
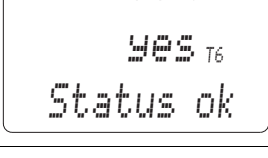
Coding	Field	Selection or range (factory settings bold)	Display	Info
T	Function group ALPHA TABLE		 <p>SETUP HOLD T ALPHA TAB</p>	Settings for temperature compensation.
T1	Select table option	<b>read</b> <i>edit</i>	 <p>SETUP HOLD <i>read</i> T1 Sel. Table</p>	
T2	Enter number of table value pairs	<b>1</b> 1 ... 10	 <p>SETUP HOLD 1 T2 No. Elem.</p>	Up to 10 value pairs can be entered in the $\alpha$ table. These are numbered from 1 ... 10 and can be edited individually or in sequence.
T3	Select table value pair	<b>1</b> 1 ... number of table value pairs <i>assign</i>	 <p>SETUP HOLD 1 T3 Sel. Elem.</p>	The function chain T3 ... T5 will run through as many times as correspond to the value in T2. "Assign" appears as the last step. After confirmation, the system jumps to T6.
T4	Enter temperature value	<b>0.0 °C</b> -35.0 ... 250.0 °C	 <p>SETUP HOLD 0.0 °C T4 Temp. val.</p>	The temperature values must have a minimum distance of 1 K. Factory setting for temperature value of value pairs in table: 0.0 °C; 10.0 °C; 20.0 °C; 30.0 °C ...
T5	Enter temperature coefficient $\alpha$	<b>2.10 %/K</b> 0.00 ... 20.00 %/K	 <p>SETUP HOLD 2.10 %/K T5 alpha val</p>	
T6	Message, whether or not the table status is ok	<b>yes</b> <i>no</i>	 <p>SETUP HOLD yes T6 Status ok</p>	Only display If status = "no", then set table correctly (all previous settings are kept) or back to measurement mode (this makes the table invalid)

### 6.4.9 Concentration measurement

You need the Plus Package to use the function group "CONCENTRATION".

The transmitter can convert conductivity values to concentration values. For this, set the operating mode to Concentration measurement (see field A1).

Then, you must enter the basic data to which the concentration calculation should refer.

You require the conductivity characteristics of the medium. To get the characteristics, you can either refer to the data sheets of the medium or determine the characteristics yourself.

1. To do so, create samples of the medium with the concentrations occurring in your process.
2. Measure the uncompensated conductivity of these samples at temperatures which likewise occur in your process.
  - For variable process temperature:
 

If the variable process temperature should be taken into account for concentration measurement, you must measure the conductivity of each created sample at two different temperatures at least (ideally at the lowest and highest process temperature). The temperature values for the various samples must be identical. However, the difference between the temperatures must be at least 0.5 °C.

At least two differently concentrated samples measured at two different temperatures are required because the transmitter needs a minimum of four references.
  - For constant process temperature:
 

Measure the differently concentrated samples at this constant process temperature. A minimum of two samples is necessary.

Finally, you should have measuring data which are similar to those shown in the following figures:

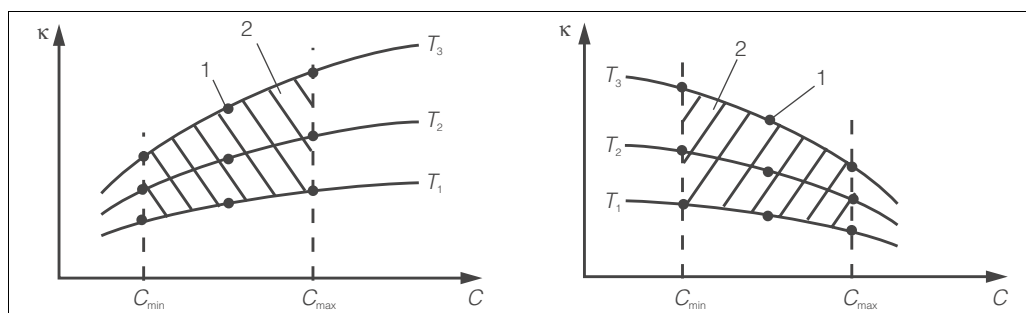

Fig. 36: Measured data for variable process temperatures (example)

κ Conductivity  
 C Concentration  
 T Temperature  
 1 Measuring point  
 2 Measuring range

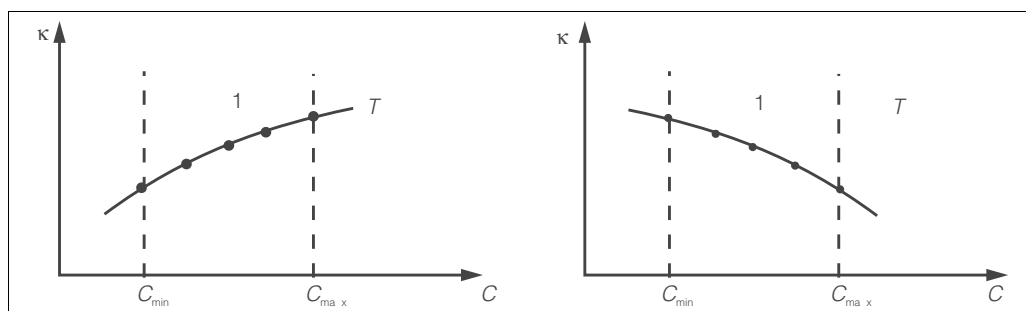

Fig. 37: Measured data for a constant process temperature (example)

κ Conductivity  
 C Concentration  
 T Constant temperature  
 1 Measuring range



**Note!**

The characteristics received from the measuring points must be strictly monotonously increasing or strictly monotonously decreasing in the range of the process conditions. Therefore, neither maxima / minima nor ranges with a constant behaviour can occur. Curve profiles such as those in Fig. 38 are not permitted.

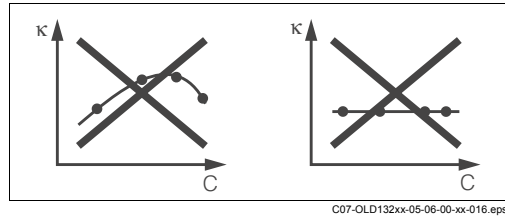

Fig. 38: Impermissible curve profiles

κ Conductivity  
C Concentration

**Value entry**

Enter the three characteristic values for each measured sample in the fields K6 to K8 (value triplets of uncompensated conductivity, temperature and concentration).

- Variable process temperature:  
Enter at least four value triplets.
- Constant process temperature:  
Enter at least two value triplets.



**Note!**

- Please make sure that the concentrations and temperatures measured for your samples correspond to the measuring range of the process. If the measured values of the process are outside the range of your sample values, this considerably reduces the level of accuracy and the error message E078 or E079 will be displayed.

If you enter an additional value triplet of 0 μS/cm and 0 % for each temperature used, you can work from the start of measuring range with sufficient accuracy and without an error message.

Enter the values in the order of increasing concentration (see the following example).

mS/cm	%	°C
240	96	60
380	96	90
220	97	60
340	97	90
120	99	60
200	99	90





- The setups for temperature compensation in the menu Setup 2 (fields B2 and B3) are inoperative for the concentration measurement. The temperature is already processed by the concentration tables.

Basic version does not include functions in *italic*.

Coding	Field	Selection or range (factory settings bold)	Display	Info
K	Function group <b>CONCENTRATION</b>			Four different concentration fields can be entered in this function group.
K1	<i>Selection of concentration curve, to be used to calculate the display value</i>	<b>1</b> 1 ... 4		The curves are independent of each other. Therefore, four different curves can be defined.

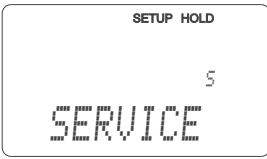
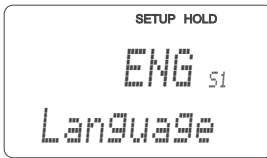
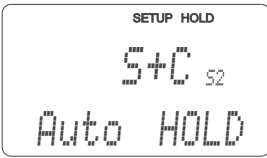
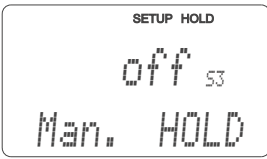
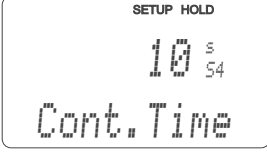
Coding	Field	Selection or range (factory settings bold)	Display	Info
K2	<i>Selection of table to be edited</i>	<b>1</b> 1 ... 4		When editing a curve, another curve should be used to calculate the corresponding values. Example: When editing curve 2, either curve 1, curve 3 or curve 4 should be active (see K1).
K3	<i>Select table option</i>	<b>read</b> <b>edit</b>		This selection applies to all concentration curves.
K4	<i>Enter number of reference triplets</i>	<b>1</b> 1 ... 10		Each triplet consists of three numeric values.
K5	<i>Select triplet</i>	<b>1</b> 1 ... number of triplets in K4 assign		Any triplet can be edited. If "assign", go to K9.
K6	<i>Enter uncompensated conductivity</i>	<b>0.0 mS/cm</b> 0.0 ... 9999 mS/cm		The function chain K5 ... K8 will run through automatically as many times as corresponds to the value in K4. Then the system jumps to K9.
K7	<i>Enter concentration value for K6</i>	<b>0.00 %</b> 0.00 ... 99.99 %		Measuring unit selected as in A2. Format selected as in A3.
K8	<i>Enter temperature value for K6</i>	<b>0.0 °C</b> -35.0 ... 250.0 °C		
K9	<i>Message whether or not the table status is ok</i>	<b>yes</b> no		Only display If not, then set table correctly (all previous settings are kept) or back to measurement mode (this makes the table invalid).

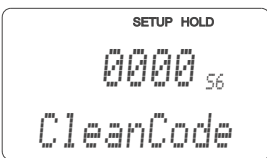
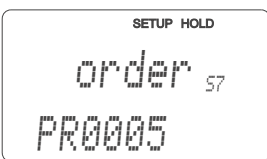
## 6.4.10 Service

Coding	Field	Setting range (Factory settings, bold)	Display	Info
S	<b>SERVICE function group</b>			Service function settings.
S1	Select language	<b>ENG = English</b> GER = German FRA = French ITA = Italian NL = Dutch ESP = Spanish		This field has to be configured once during device configuration. Then you can exit S1 and continue.
S2	Configure Hold	<b>S+C = Hold during configuration and calibration</b> Cal = Hold during calibration Setup = Hold during configuration None = no Hold		S = setup C = calibration
S3	Manual Hold	<b>Off</b> On		The setting is retained even in the event of a power failure.
S4	Enter Hold dwell period	<b>10 s</b> 0 ... 999 s		
S5	Enter SW upgrade release code (Plus Package)	<b>0000</b> 0000 ... 9999		The code is located on the nameplate. If an incorrect code is entered, you are taken back to the measurement menu. The number is edited with the PLUS or MINUS key and confirmed with the ENTER key. "1" is displayed if the code is active.
S6	Enter SW upgrade release code Chemoclean	<b>0000</b> 0000 ... 9999		The code is located on the nameplate. If an incorrect code is entered, you are taken back to the measurement menu. The number is edited with the PLUS or MINUS key and confirmed with the ENTER key. "1" is displayed if the code is active.
S7	Order number is displayed			If the device is upgraded, the order code is <b>not</b> automatically adjusted.
S8	Serial number is displayed			

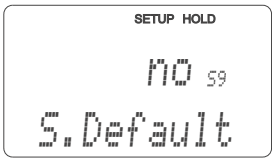
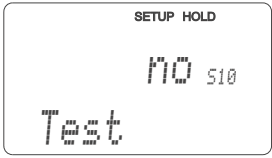
Coding		Field	Setting range (Factory settings, bold)	Display	Info
	S9	Reset the device to the basic settings 	<b>No</b> Sens = sensor data Facyt = factory settings		Sens = last calibration is deleted and is reset to factory setting. Facyt = all data (apart from A1 a. S1) are deleted and reset to the factory setting!
	S10	Perform device test	<b>No</b> Displ = display test		

### 6.4.11 Service 2

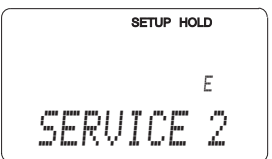
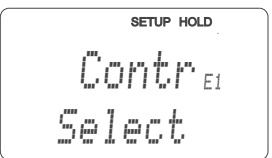
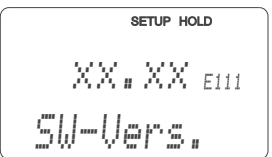
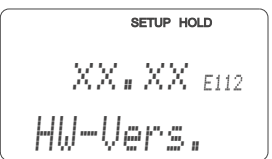
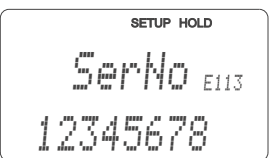
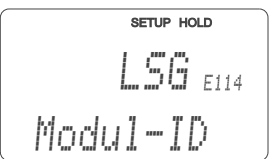
Coding		Field	Setting range (Factory settings, bold)	Display	Note	
	E	<b>SERVICE 2 function group</b>			Information on the device version	
	E1	Select module	<b>Contr = controller (1)</b> Trans = transmitter (2) Main = power unit (3) Rel = relay module (4)			
		E111 E121 E131 E141 E151	Software version is displayed			If E1 = contr: instrument software If E1 = trans, main, rel: module firmware If E1 = sens: sensor software
		E112 E122 E132 E142 E152	Hardware version is displayed			Only display function
		E113 E123 E133 E143 E153	Serial number is displayed			Only display function
E114 E124 E134 E144 E154	Module ID is displayed			Only display function		

### 6.4.12 Interfaces

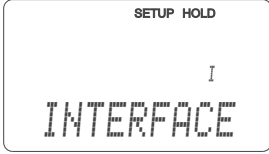
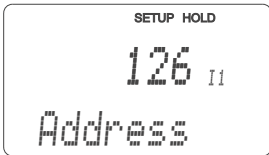
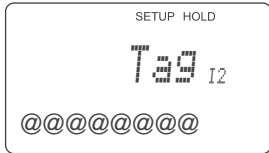
Coding	Field	Setting range (Factory settings, bold)	Display	Info
I	<b>INTERFACE</b> function group			Communication settings (only for device version HART or PROFIBUS).
I1	Enter bus address	Address HART: <b>0</b> ... 15 or PROFIBUS: 0 ... <b>126</b>		Each address may only be given once in a network. If a device address ≠ 0 is selected, the current output is automatically set to 4 mA and the device is set to multi-drop operation.
I2	Display of measuring point			

## 6.5 Communication

For devices with a communication interface, please also refer to the separate Operating Instructions BA208e00 (HART®) or BA209e00 (PROFIBUS®).

## 6.6 Calibration

To access the "Calibration" function group, press the CAL key.  
 This function group is used to calibrate and adjust the transmitter. Two different types of calibration are possible:

- Calibration by measurement in a calibration solution of a known conductivity.
- Calibration by entering the exact cell constant of the conductivity sensor.





Note!

- At first start-up of inductive sensors, an airset is absolutely required in order for the measuring system to be able to generate accurate measuring values.
- If the calibration procedure is aborted by pressing the PLUS and MINUS keys at the same time (return to C114, C126 or C136) or if the calibration is faulty, then the previous calibration data are reinstated. A calibration error is indicated by the "ERR" message and flashing of the sensor symbol on the display.  
 Repeat calibration!
- The instrument is automatically switched to hold during calibration (factory setting).
- After calibration, the system jumps back to the measuring mode. During the hold dwell period the hold symbol is displayed.
- For conductive sensors only the fields C121 to C126 are relevant.

Basic version does not include functions in *italic*.

Coding	Field	Selection or range (factory settings bold)	Display	Info
C	<b>Function group CALIBRATION</b>			Calibration settings.
C1 (1)	Calibration of inductive sensors with a ring-shaped opening	<b>Airs = Airset (1)</b> Cellc = cell constant (2) InstF = installation factor (3)		When commissioning inductive sensors, an airset is mandatory. The calibration of the sensor is to be performed in air. The sensor must be dry.
	Remove sensor from the medium and dry <b>completely</b> .			
C111	Residual coupling start calibration (airset)	<b>current measured value</b>		Start calibration with CAL.
C112	Residual coupling is displayed (airset)	-80.0 ... 80.0 µS/cm		Residual coupling of measuring system (sensor and transmitter).

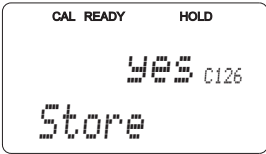
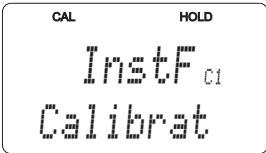
Coding		Field	Selection or range (factory settings bold)	Display	Info
	C113	Calibration status is displayed	o.k. E xxx		If the calibration status is not o.k., the second display line shows an explanation of the error.
	C114	Store calibration results?	<b>yes</b> no new		If C113 = E xxx, then only no or <b>new</b> . If new, return to C. If yes/no, return to "Measurement".
	C1 (2)	Calibration of cell constant	Airs = Airset (1) <b>Cellc = cell constant</b> (2) InstF = installation factor (3)		
Immerse sensor in calibration solution. <b>Note!</b> This describes the calibration for temperature compensated conductivity. For calibration with uncompensated conductivity set the temperatur coefficient $\alpha$ to 0.					The sensor should be immersed at a sufficient distance from the vessel wall (installation factor has no influence if a > 15 mm / 0.59").
	C121	Enter calibration temperature (MTC)	<b>25 °C</b> -35.0 ... 250.0 °C		Only exists if B1 = fixed.
	C122	Enter $\alpha$ value of calibration solution	<b>2.10 %/K</b> 0.00 ... 20.00 %/K		This value is specified in the Technical Information of all calibration solutions. You can also use the printed-on table to calculate the value. Set $\alpha$ to 0 for calibration with uncompensated values.
	C123	Enter correct conductivity value of calibration solution	<b>current measured value</b> 0.0 $\mu$ S/cm ... 9999 mS/cm		You should select a value close to the application range.
	C124	Calculated cell constant is displayed	0.0025 ... 99.99 $\text{cm}^{-1}$		The calculated cell constant is displayed and entered in A5.
	C125	Calibration status is displayed	o.k. E xxx		If the calibration status is not o.k., the second display line shows an explanation of the error.

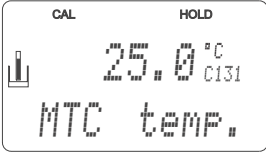
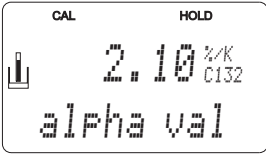
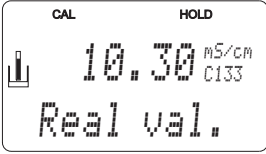
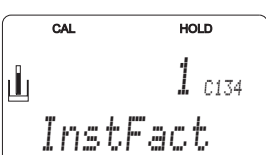
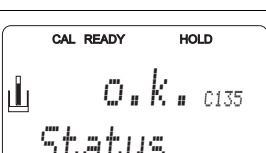
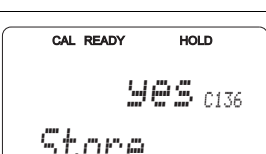
Coding		Field	Selection or range (factory settings bold)	Display	Info
	C126	Store calibration results?	<b>yes</b> no new		If C125 = E xxx, then only no or <b>new</b> . If new, return to C. If yes/no, return to "Measurement".
	C1 (3)	<i>Calibration with sensor adaptation for inductive sensors (Plus Package only)</i>	Airs = Airset (1) Cellc = cell constant (2) <b>InstF = installation factor</b> (3)		Sensor calibration with compensation of wall influence. On inductive sensors, the distance from the sensor to the wall of the pipe and the material of the pipe (conductive or nonconductive) influence the measured value. The installation factor shows this influence. See the technical information of the installed sensor.
	The sensor is installed in the process.				
	C131	<i>Enter process temperature (MTC)</i>	<b>25 °C</b> -35.0 ... 250.0 °C		Only exists if B1 = fixed.
	C132	<i>Enter α value of the calibration solution</i>	<b>2.10 %/K</b> 0.00 ... 20.00 %/K		This value is specified in the TI of all calibration solutions. You can also use the printed-on table to calculate the value. Set α to 0 for calibration with uncompensated values.
	C133	<i>Enter correct conductivity value of the calibration solution</i>	<b>current measured value</b> 0.0 μS/cm ... 9999 mS/cm		You should select a value close to the application range.
	C134	<i>Calculated installation factor is displayed</i>	<b>1</b> 0.10 ... 5.00		On inductive sensors, the distance from the sensor to the wall of the pipe and the material of the pipe (conductive or nonconductive) influence the measured value. The installation factor shows this influence. See the technical information of the installed sensor.
	C135	<i>Calibration status is displayed</i>	o.k. E xxx		If the calibration status is not o.k., the second display line shows an explanation of the error.
	C136	Store calibration results?	<b>yes</b> no new		If C135 = E xxx, then only no or <b>new</b> . If new, return to C. If yes/no, return to "Measurement".

## 7 Maintenance

Take all the necessary measures in time to guarantee the operational safety and reliability of the entire measuring system.

Maintenance work at the transmitter comprises:

- Calibration (see "Calibration" section)
- Cleaning of assembly and sensor
- Cable and connection check



Warning!

- When carrying out all work on the device, please observe any possible effects on the process control or the process itself.
- When removing the sensor during maintenance or calibration, please consider potential hazards due to pressure, high temperatures and contamination.
- Make sure the device is de-energised before you open it.  
If work must be carried out when the device is live, this may only be performed by an electrical technician!
- Switching contacts can be fed by separate circuits. These circuits must also be de-energised before work on the terminals is performed.



Caution ESD!

- Electronic components are sensitive to electrostatic discharge. Personal protective measures such as discharging at the PE beforehand or permanent grounding with a wrist strap are required.
- For your own safety, use only genuine spare parts. With genuine spare parts, the function, accuracy and reliability are also guaranteed after repair.



Note!

If you have any queries, please contact your local Sales Office.

### 7.1 Maintenance of the entire measuring point

#### 7.1.1 Cleaning the transmitter

Clean the front of the housing with usual commercial cleaning agents.

In accordance with DIN 42 115, the front is resistant to:

- Isopropanol
- Diluted acids (max. 3%)
- Diluted alkalis (max. 5%)
- Esters
- Hydrocarbons
- Ketones
- Household cleaners



Caution!

For cleaning purposes, never use:

- Concentrated mineral acids or alkalis
- Benzyl alcohol
- Methylene chloride
- High-pressure steam

### 7.1.2 Cleaning the conductivity sensors

Please clean **contamination on the sensor** as follows:

- Oily and greasy films:  
Clean with detergent (grease solvers, such as alcohol, acetone, poss. washing-up liquids).



Warning!

When using the following cleaning agents, make sure to protect your hands, eyes and clothing!

- Lime and metal hydroxide layers:  
Dissolve layers with diluted hydrochloric acid (3 %) and then rinse carefully with a lot of clear water.
- Layers containing sulphide (from flue gas desulphurising or sewage treatment plants):  
Use mixture of hydrochloric acid (3 %) and thiocarbamide (usual commercial) and then rinse carefully with a lot of clear water.
- Layers containing proteins (e.g. food industry):  
Use mixture of hydrochloric acid (0.5 %) and pepsin (usual commercial) and then rinse carefully with a lot of clear water.

### 7.1.3 Simulation of conductive sensors for device test

Check a measuring device for conductivity by replacing the measuring section and temperature sensor with resistors. Simulation accuracy is dependent on the accuracy of the resistors.

#### Temperature

The values in the right-hand table are valid, if no temperature offset is set on the transmitter.

With the temperature sensor type Pt 1000, all the resistance values are increased by a factor of 10.

 Note!

- Connect the temperature equivalent resistor in a three-line system.
- To connect decade resistors instead of the conductivity sensor, you can use the "Conductivity Test Adapter" service kit (order no. 51500629).

Pt 100 replacement resistors	
Temperature (°C/ °F)	Resistance value
-20/-4	92.13 Ω
-10/14	96.07 Ω
0/32	100.00 Ω
10/50	103.90 Ω
20/68	107.79 Ω
25/77	109.73 Ω
50/122	119.40 Ω
80/176	130.89 Ω
100/212	138.50 Ω
200/392	175.84 Ω

**Conductivity**

For conductivity, the values in the following table are valid, if the cell constant k is set to the nominal value according to column 2.

Otherwise: Display conductivity[mS/cm] =  $k[\text{cm}^{-1}] \cdot 1 / R[\text{k}\Omega]$

Resistance R	Cell constant k	Display for conductivity	Display for MΩ
10 Ω	1 cm <sup>-1</sup>	100 mS/cm	
	10 cm <sup>-1</sup>	1000 mS/cm	
100 Ω	0.1 cm <sup>-1</sup>	1 mS/cm	1 kΩ · cm
	1 cm <sup>-1</sup>	10 mS/cm	
	10 cm <sup>-1</sup>	100 mS/cm	
1000 Ω	0.1 cm <sup>-1</sup>	0.1 mS/cm	10 kΩ · cm
	1 cm <sup>-1</sup>	1 mS/cm	
	10 cm <sup>-1</sup>	10 mS/cm	
10 kΩ	0.01 cm <sup>-1</sup>	1 μS/cm	1 MΩ · cm
	0.1 cm <sup>-1</sup>	10 μS/cm	100 kΩ · cm
	1 cm <sup>-1</sup>	100 μS/cm	
	10 cm <sup>-1</sup>	1 mS/cm	
100 kΩ	0.01 cm <sup>-1</sup>	0.1 μS/cm	10 MΩ · cm
	0.1 cm <sup>-1</sup>	1 μS/cm	1 MΩ · cm
	1 cm <sup>-1</sup>	10 μS/cm	
1 MΩ	0.01 cm <sup>-1</sup>	0.01 μS/cm	100 MΩ · cm
	0.1 cm <sup>-1</sup>	0.1 μS/cm	10 MΩ · cm
	1 cm <sup>-1</sup>	1 μS/cm	
10 MΩ	0.01 cm <sup>-1</sup>	0.001 μS/cm	
	0.1 cm <sup>-1</sup>	0.01 μS/cm	100 MΩ · cm



**Note!**

The MΩ measurement is normally used for pure and ultrapure water and therefore is only wise for cell constants where  $k = 0.01$  or  $k = 0.1 \text{ cm}^{-1}$ .

### 7.1.4 Simulation of inductive sensors for device test

The inductive sensor cannot be simulated.

However, the overall system comprising the transmitter and inductive sensor can be checked using equivalent resistances. Note the cell constant ( $k_{\text{nominal}} = 1.98 \text{ cm}^{-1}$  for OLS 50,  $k_{\text{nominal}} = 5.9 \text{ cm}^{-1}$  for OLS 52).

For an accurate simulation, the actual cell constant (can be read in field C124) is to be used to calculate the display value:

Display conductivity [mS/cm] =  $k(\text{cm}^{-1}) \cdot 1/R [\text{k}\Omega]$ .

Values for simulation with OLS 50 at 25 °C / 77 °F:

Simulation resistance R	Default cell constant k	Conductivity display
2 $\Omega$	1.98 $\text{cm}^{-1}$	990 mS/cm
10 $\Omega$	1.98 $\text{cm}^{-1}$	198 mS/cm
100 $\Omega$	1.98 $\text{cm}^{-1}$	19.8 mS/cm
1 k $\Omega$	1.98 $\text{cm}^{-1}$	1.98 mS/cm

#### Conductivity simulation:

Pull a cable through the sensor opening and then connect, e.g. to a decade resistor.

### 7.1.5 Check of conductive sensors

- Measuring surface connection:  
The measuring surfaces are directly connected to the connections of the sensor connector. Check with ohmmeter at  $< 1 \Omega$ .
- Measuring surface shunt:  
There may not be any shunt between the measuring surfaces. Check with ohmmeter at  $> 20 \text{ M}\Omega$ .
- Temperature sensor shunt:  
There may not be any shunt between the measuring surfaces and the temperature sensor. Check with ohmmeter at  $> 20 \text{ M}\Omega$ .
- Temperature sensor:  
You can find out the type of the temperature sensor being used by consulting the sensor nameplate. The sensor can be checked at the sensor connector with an ohmmeter:
  - Pt 100 at 25 °C / 77 °F = 109.79  $\Omega$
  - Pt 1000 at 25 °C / 77 °F = 1097.9  $\Omega$
  - NTC 30 k at 25 °C / 77 °F = 30 k $\Omega$
- Connection:  
For sensors with a terminal connection (OLS12/13) check the assignment of the terminals for reversals and the tightness of the terminal screws.

### 7.1.6 Check of inductive sensors

The following specifications apply to the OLS50 and OLS52 sensors.

The sensor lines on the instrument or junction box are to be disconnected for all tests described here!

- Testing transmitting and receiving coils
  - Ohmic resistance approx. 0.5 ... 2  $\Omega$ .
  - Inductivity approx. 260 ... 450 mH (at 2 kHz)
    - OLS50: approx. 250 ... 450 mH
    - OLS52: approx. 180 ... 360 mH

(Measure the white and red coaxial cables, between the inner conductor and screen in both cases.)
- Testing the coil shunt
  - A shunt between the two sensor coils is not allowed. The resistance measured should be >20 M $\Omega$ .

Test with ohmmeter between red coaxial cable and white coaxial cable.
- Testing the temperature sensor
  - Use the table in chapter "Simulation of inductive sensors for device test" to check the Pt100 in the sensor.
  - Measure between the green and white wires and between green and yellow. The resistance values should be identical.
- Testing the temperature sensor shunt
  - Shunts between the temperature sensor and the coils are not allowed. Check with ohmmeter for >20 M $\Omega$ .
  - Measure between the temperature sensor wires (green + white + yellow) and the coils (red and white coaxial cables).

### 7.1.7 Connecting lines and junction boxes

- Use the methods described in chapters "Simulation of conductive/inductive sensors for device test" to perform a quick functional check from the conductivity sensor (sensor connector) to the measuring instrument via an extension.
  - Connect the decade resistors simply with the service kit "Conductivity Test Adapter", order no. 51500269.
- Check junction boxes for:
  - Moisture (influence at low conductivity or M $\Omega$  measurement, if necessary dry box, replace seals, insert dehydrating bag)
  - Correct connection of all lines
  - Connection of the outer screens
  - Tightness of the terminal screws

## 7.2 "Optoscope" service tool

The Optoscope together with the "Scopeware" software offers the following possibilities, without having to remove or open the transmitter and without galvanic connection to the instrument:

- Documentation of the instrument settings in conjunction with Commuwin II
- Software update by the service technician
- Upload/download a hex dump to duplicate configurations.

The Optoscope serves as an interface between the transmitter and PC / laptop. The information exchange takes place via the optical interface on the transmitter and via an RS 232 interface on the PC / laptop (see "Accessories").

## 8 Accessories

### 8.1 Sensors

- OLS12  
Conductive conductivity sensor for standard, Ex and high temperature applications;  
Ordering acc. to version, see Technical Information TI082e00
- OLS13  
Conductive conductivity sensor for standard, Ex and high temperature applications;  
Ordering acc. to version, see Technical Information TI083e00
- OLS15  
Conductive conductivity sensor for pure and ultra-pure water applications (incl. Ex);  
Ordering acc. to version, see Technical Information TI109e00
- OLS16  
Hygienic conductive conductivity sensor for pure and ultra-pure water applications (incl. Ex);  
Ordering acc. to version, see Technical Information TI 27e00
- OLS19  
Conductive conductivity sensor for pure and ultra-pure water applications;  
Ordering acc. to version, see Technical Information TI110e00
- OLS21  
Conductive conductivity sensor for applications with middle to high conductivity  
(incl. Ex); Ordering acc. to version, see Technical Information TI085e00
- OLS50  
Inductive conductivity sensor for standard, Ex and high temperature applications;  
Ordering acc. to the sensor version, see Technical Information TI118e00
- OLS52  
Inductive conductivity sensor with short response time in hygienic design;  
Ordering acc. to the sensor version, see Technical Information TI167e00

### 8.2 Connection accessories

- OYK71 measuring cable  
for use as extension cable between junction box VBM and transmitter, sold by the metre;  
order no. 50085333
- Extension cable OLK5  
for inductive conductivity sensors, for cable extension via junction box VBM;  
(sold by the metre), order no. 50085473
- Junction box VBM  
for cable extension, with 10 terminals, IP 65 / NEMA 4X

Cable entry Pg 13.5

Order no. 50003987

Cable entry NPT ½"

Order no. 51500177

### 8.3 Mounting accessories

- Weather protection cover OYY101 for mounting of field housing, for outdoor installation  
material: stainless steel 1.4031;  
order no. OYY101-A

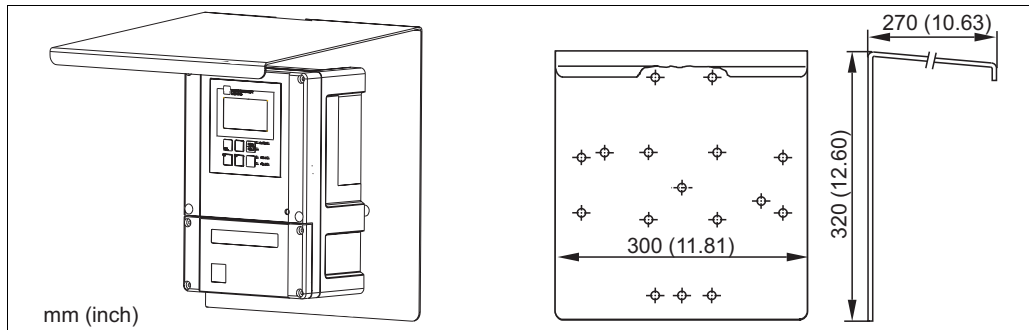

a0005585

Fig. 39: Weather protection cover for field instrument

- Universal upright post OYY102  
Square post for mounting of field housing, material: stainless steel 1.4301;  
order no. OYY102-A

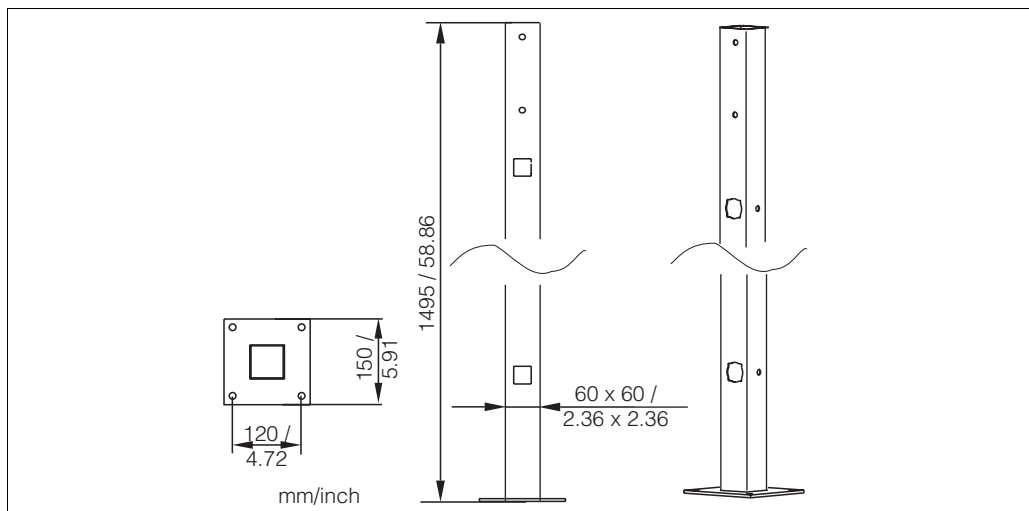

C07-CYY102xx-00-06-00-en-002.eps

Fig. 40: Square post OYY102

- Kit for mounting of field housing on horizontal or vertical pipes (Ø max. 60 mm (2.36")) order no. 50086842

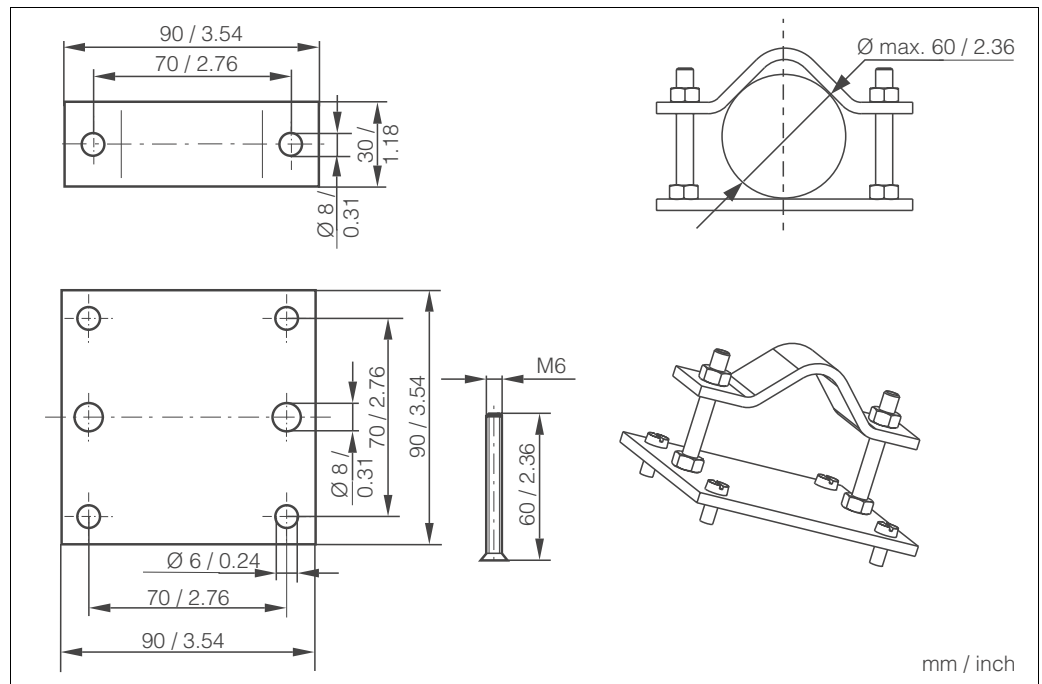

C07-OxM2x3xx-00-06-00-en-001.eps

Fig. 41: Pipe mounting kit

### 8.4 Assemblies

- OLA111 immersion and process assembly  
For open and closed tanks with DN 100 flange,  
for ordering information, see Technical Information OLA111 (TI135e00)

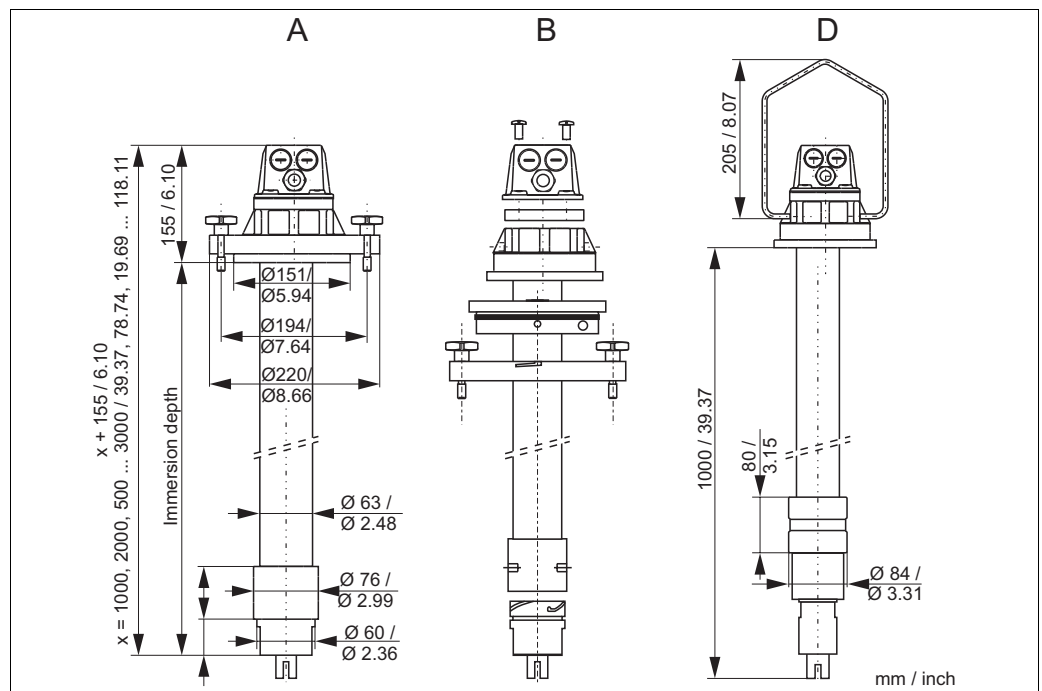

a0003435-en

Fig. 42: OLA111, DN 100 flange, mounting versions A, B und D

- OLA140  
For the inductive sensor OLS50  
Immersion assembly with flange connection for high duty processes;  
Ordering acc. to the version, see Technical Information (TI196e00)
- OLA751 flow assembly

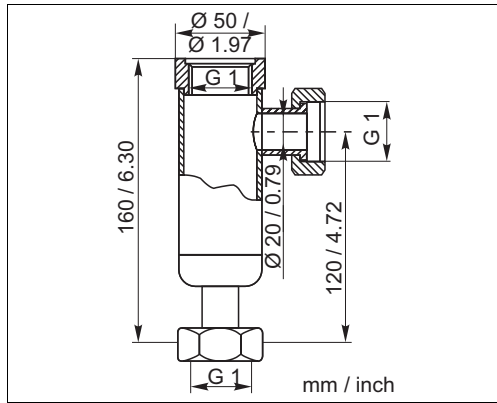

Fig. 43: OLA751 flow assembly

For installation of conductivity sensors with G 1 thread.

Inlet (bottom) and outlet (lateral) DN 20 with union nuts G 1.

Stainless steel 1.4571 (AISI 316Ti)

Max. temperature: 160 °C / 320 °F

Max. pressure: 12 bar / 174 psi

Order no.: 50004201

## 8.5 Software and hardware add-ons

The add-ons can only be ordered by quoting the serial number of the device in question.

- Plus Package  
Order no. 51500385
- Chemoclean  
Order no. 51500963
- Two-relay card  
Order no. 51500320
- Four-relay card  
Order no. 51500321
- Two-relay card with current input  
Order no. 51504304
- Four-relay card with current input  
Order no. 51504305

## 8.6 Calibration solutions

Precision calibration solutions, acc. to SRM (Standard reference material) of NIST, error limit  $\pm 0.5\%$ , reference temperature 25 °C (77 °F), with temperature table

- OLY11-A, 74.0  $\mu\text{S}/\text{cm}$ , 500 ml (0.132 Us.gal); order no. 50081902
- OLY11-B, 149.6  $\mu\text{S}/\text{cm}$ , 500 ml (0.132 Us.gal); order no. 50081903
- OLY11-C, 1.406  $\text{mS}/\text{cm}$ , 500 ml (0.132 Us.gal); order no. 50081904
- OLY11-D, 12.64  $\text{mS}/\text{cm}$ , 500 ml (0.132 Us.gal); order no. 50081905
- OLY11-E, 107.0  $\text{mS}/\text{cm}$ , 500 ml (0.132 Us.gal); order no. 50081906

## 8.7 Optoscope

- Optoscope  
Interface between transmitter and PC / laptop for service purposes.  
The Windows software "Scopeware" required for the PC or laptop is supplied with the Optoscope. The Optoscope is supplied in a sturdy plastic case with all the accessories required.  
Order no. 51500650

## 9 Trouble-shooting

### 9.1 Trouble-shooting instructions

The transmitter constantly monitors its functions itself. If an error occurs which the device recognises, this is indicated on the display. The error number is under the unit display of the main measured value. If more than one error occurs, you can call these up with the MINUS key. Refer to the "System error messages" table for the possible error numbers and remedial measures.

Should a malfunction occur without any transmitter error message, please refer to the "Process-specific errors" or the "Device-specific errors" tables to localise and rectify the error. These tables provide you with additional information on any spare parts required.

### 9.2 System error messages

The system error messages can be called up and selected with the MINUS key.

Error no.	Display	Tests and/or remedial measures	Alarm contact		Error current		Autom. cleaning start	
			Facty	User	Facty	User	Facty	User
E001	EEPROM memory error	1. Switch device off and then on again.	Yes		No		—	— <sup>1</sup>
E002	Instrument not calibrated, calibration data invalid, no user data, user data invalid (EEPROM error), instrument software not suitable to hardware (controller)	2. Load device software compatible with the hardware (with optoscope, see "Optoscope service tool" section). 3. Load measurement-parameter specific device software. 4. If the error persists, send in the device for repair to your local service organisation or replace the device.	Yes		No		—	— <sup>1</sup>
E003	Download error	Invalid configuration. Repeat download, check optoscope.	Yes		No		No	
E004	Instrument software version not compatible with module hardware version	Load software compatible with hardware. Load measurement-parameter specific device software.	Yes		No		No	
E007	Transmitter malfunction, instrument software not compatible with transmitter version		Yes		No		—	— <sup>1</sup>
E008	Sensor or sensor connection faulty	Check sensor and sensor connection (Service).	Yes		No		No	
E010	Temperature sensor defective, not connected or short-circuited (measurement continues with 25 °C)	Check temperature sensor and connections; check device and measuring cable with temperature simulator if necessary. Check correct option selected in field B1.	Yes		No		No	
E025	Limit for Airset offset exceeded	Repeat Airset (in air) or replace sensor. Dry sensor.	Yes		No		No	
E036	Calibration range of sensor exceeded	Clean sensor and recalibrate; if necessary, check sensor and connections.	Yes		No		No	
E037	Below calibration range of sensor		Yes		No		No	
E045	Calibration aborted	Recalibrate	Yes		No		—	— <sup>1</sup>

Error no.	Display	Tests and/or remedial measures	Alarm contact		Error current		Autom. cleaning start	
			Facty	User	Facty	User	Facty	User
E049	Calibration range of installation factor exceeded	Check pipe diameter, clean sensor and recalibrate.	Yes		No		—	— <sup>1</sup>
E050	Below calibration range of installation factor		Yes		No		—	— <sup>1</sup>
E055	Below main parameter measuring range	Immerse sensor in conductive medium or perform Airset	Yes		No		No	
E057	Main parameter measuring range exceeded	Check measurement and connections; check device and measuring cable with simulator if necessary.	Yes		No		No	
E059	Below temperature measuring range		Yes		No		No	
E061	Temperature measuring range exceeded		Yes		No		No	
E063	Below current output range 1	Check configuration.	Yes		No		No	
E064	Current output range 1 exceeded	Check measured value and current assignment.	Yes		No		No	
E065	Below current output range 2		Yes		No		No	
E066	Current output range 2 exceeded		Yes		No		No	
E067	Set point exceeded limit contactor 1	Check configuration.	Yes		No		No	
E068	Set point exceeded limit contactor 2		Yes		No		No	
E069	Set point exceeded limit contactor 3		Yes		No		No	
E070	Set point exceeded limit contactor 4		Yes		No		No	
E071	Inaccurate measurement / polarisation	Clean sensor; check table; choose suitable sensor	Yes		No		No	
E077	Temperature outside $\alpha$ value table range	Clean sensor; check table.	Yes		No		No	
E078	Temperature outside concentration table		Yes		No		No	
E079	Conductivity outside concentration table		Yes		No		No	
E080	Current output 1 range too small	Increase range in "Current outputs" menu.	No		No		—	— <sup>1</sup>
E081	Current output 2 range too small		No		No		—	— <sup>1</sup>
E085	Incorrect setting for error current	If the current range "0 ... 20 mA" was selected in field O311, the error current "2.4 mA" may not be set.	?		?		?	?
E100	Current simulation active		No		No		—	— <sup>1</sup>
E101	Service function yes	Switch off service function or switch device off and then on again.	No		No		—	— <sup>1</sup>
E102	Manual mode active		No		No		—	— <sup>1</sup>
E106	Download yes	Wait for download to finish.	No		No		—	— <sup>1</sup>
E116	Download error	Repeat download.	No		No		—	— <sup>1</sup>
E150	Distance between temp. values in $\alpha$ value table too small or not monotonously increasing	Enter correct values in $\alpha$ value table (minimum distance between temperature values of 1 K required)	No		No		No	
E151	USP/EP error		No		No		No	

Error no.	Display	Tests and/or remedial measures	Alarm contact		Error current		Autom. cleaning start	
			Facty	User	Facty	User	Facty	User
E152	PCS alarm	Check sensor and connection.	No		No		No	
E153	USP/EP temperature error		No		No		No	
E154	Below lower alarm threshold for period exceeding alarm delay	Perform manual comparison measurement if necessary. Service sensor and recalibrate.	Yes		No		No	
E155	Above upper alarm threshold for period exceeding alarm delay		Yes		No		No	
E156	Actual value undershoots alarm threshold (CC setpoint) for longer than the set permissible maximum period		Yes		No		No	
E157	Actual value exceeds alarm threshold (CC setpoint) for longer than the set permissible maximum period		Yes		No		No	
E162	Dosage stop	Check settings in the CURRENT INPUT and CHECK function groups.	Yes		No		No	
E171	Flow in main stream too low or zero	Restore flow.	Yes		No		No	
E172	Switch-off limit for current input exceeded	Check process variables at sending measuring instrument. Change range assignment if necessary.	Yes		No		No	
E173	Current input < 4 mA	Check process variables at sending measuring instrument.	Yes		No		No	
E174	Current input > 20 mA	Check process variables at sending measuring instrument. Change range assignment if necessary.	Yes		No		No	

1) If this error occurs, there is no possibility of starting a cleaning session (field F8 not applicable with this error).

### 9.3 Process specific errors

Use the following table to locate and correct errors.

Error	Possible cause	Tests and / or remedial measures	Equipment, spare parts, personnel
Display deviates from reference measurement	Calibration faulty	Calibrate instrument according to chapter "Calibration".	Calibration solution or sensor certificate
	Sensor soiled	Clean sensor.	See chapter "Cleaning conductivity sensors".
	Incorrect temperature measurement	Check temperature value on instrument and reference unit.	Temperature measuring instrument, precision thermometer
	Incorrect temperature compensation	Check compensation method (none / ATC / MTC) and compensation type (linear/substance/user table).	Please note: transmitter has separate calibration and operating temperature coefficients.
	Reference instrument calibration faulty	Calibrate reference instrument or use calibrated instrument.	Calibration solution, operating instructions of reference instrument
	Incorrect ATC setting on reference instrument	Compensation method and compensation type must be identical on both instruments.	Operating instructions of reference instrument
	Polarisation error	Use suitable sensor: <ul style="list-style-type: none"> <li>• Use larger cell constant.</li> <li>• Use graphite instead of stainless steel (check resistance).</li> </ul>	Measuring range tables e.g. in FA "Conductivity" or technical data of conductivity sensors
	Incorrect line resistance in field A6	Enter correct value	OYK71: 165 Ω/km
Implausible measured values in general: – continuous measured value overflow – measured value always 000 – measured value too low – measured value too high – measured value frozen – incorrect current output value	Short circuit / moisture in sensor	Check sensor.	See chapter "Checking inductive conductivity sensors".
	Short circuit in cable or junction box	Check cable and junction box.	See chapter "Checking extension cable and junction box".
	Interruption in sensor	Check sensor.	See chapter "Checking inductive conductivity sensors".
	Interruption in cable or junction box	Check cable and junction box.	See chapter "Checking extension cable and junction box".
	Incorrect cell constant setting	Check cell constant.	Sensor nameplate or certificate
	Incorrect output assignment	Check assignment of measured values to current signals.	
	Incorrect output function	Check 0-20 / 4 -20 mA selection and curve shape (linear /table).	
	Air cushion in assembly	Check assembly and installation.	
	Grounding short on or in device	Measure in insulated container	Plastic container, calibration solutions
	Transmitter module defective	Test with new module.	See chapter "Spare parts".
Incorrect temperature value	Impermissible instrument operating state (no response to key actuation)	Switch instrument off and back on.	EMC problem: check grounding and line routing if problem persists or call responsible Service to test.
	Incorrect sensor connection	Verify connections using connection diagram; three-wire connection mandatory.	Connection diagram in chapter "Electrical connection"
	Measuring cable defective	Check cable for interruption/short circuit/ shunt.	Ohmmeter
	Incorrect temperature sensor type	Select temperature sensor type on instrument (field B1).	

Error	Possible cause	Tests and / or remedial measures	Equipment, spare parts, personnel
Incorrect conductivity measured value in process	No / incorrect temperature compensation	ATC: select compensation type; linear: set correct coefficient. MTC: set process temperature.	
	Incorrect temperature measurement	Check temperature value.	Reference instrument, thermometer
	Bubbles in medium	Suppress bubble formation: – gas bubble trap – counterpressure (cover) – bypass measurement	
	Polarisation effects (only with conductive sensors)	Use suitable sensor • Use larger cell constant • Use graphite instead of stainless steel (check resistance)	Measuring range tables e.g. in FA "Conductivity" or technical data of conductivity sensors
	Flow rate too high (may cause bubbles)	Reduce flow or choose low turbulence mounting position.	
	Interference current in medium (only when conductive)	Ground medium close to sensor.	Most frequent cause of currents in medium: defective submerged motors
	Sensor soiled or coated	Clean sensor (see chapter "Cleaning conductivity sensors").	Heavily soiled media: use spray cleaning.
	Incorrect line resistance in field A6	Enter correct value.	OYK71: 165 Ω/km
Measured value fluctuates	Measuring cable interferences	Connect cable screen according to connection diagram.	See chapter "Electrical connection".
	Signal output line interferences	Check line routing, try separate line routing.	Separate routing of signal output and measuring input lines
	Interference currents in medium	Eliminate source of interference or ground medium close to sensor.	
Controller or timer cannot be activated	No relay module available	Install module LSR1-2 or LSR1-4.	
Controller/limit contact does not work	Controller switched off	Activate controller.	See fields R2xx.
	Controller in "Manual/Off" mode	Choose "Auto" or "Manual/On" mode.	Keyboard, REL-key
	Pickup delay setting too long	Disable or shorten pickup delay.	See fields R2xx.
	"Hold" function active	"Automatic Hold" during calibration, "Hold" input activated; "Hold" via keyboard active.	See fields S2 to S5.
Controller/limit contact works continuously	Controller in "Manual/On" mode	Set controller to "Manual/Off" or "Auto".	Keyboard, REL and AUTO keys
	Dropout delay setting too long	Shorten dropout delay.	See field R2xx.
	Control loop interruption	Check measured value, current output, actuators, chemical supply.	
No conductivity current output signal	Line open or short-circuited	Disconnect line and measure directly on instrument.	mA meter 0–20 mA
	Output defective	See chapter "Instrument specific errors".	
Fixed conductivity current output signal	Current simulation active	Switch off simulation.	See field O3.
	Impermissible operating state of processor system	Switch instrument off and back on.	EMC problem: check installation, screen, grounding if problem persists / call responsible Service to test.

Error	Possible cause	Tests and / or remedial measures	Equipment, spare parts, personnel
Incorrect current output signal	Incorrect current assignment	Check current assignment: 0–20 mA or 4–20 mA?	Field O311
	Total load in current loop excessive (> 500 Ω.)	Disconnect output and measure directly on instrument.	mA meter for 0–20 mA DC
	EMC (interference coupling)	Disconnect both output lines and measure directly on instrument.	Use shielded lines, ground screens on both sides, route line in other duct if necessary.
Current output table not accepted	Value interval too small	Select practical intervals	
No temperature output signal	Instrument does not have 2nd current output	Refer to nameplate for variant; change LSCH-x1 module if necessary.	Module LSCH-x2, see chapter "Spare parts".
	Instrument with PROFIBUS PA	PA instrument has no current output!	
Chemoclean function not available	No relay module (LSR1-x) installed or only LSR1-2 available	Install LSR1-4 module. The Chemoclean is enabled using the release code supplied by your supplier in the Chemoclean retrofit kit.	Module LSR1-4, see chapter "Spare parts".
Plus package functions not available (Live Check, current curve 2 ... 4, alpha value curve 2 ... 4, user conc. curve 1 ... 4)	Plus package not enabled (enable with code that depends on serial number and is received from your supplier with order of extension package)	<ul style="list-style-type: none"> <li>– When upgrading instrument with Plus package: code received from your supplier ⇒ enter.</li> <li>– After replacing defective LSCH/ LSCP module: first enter instrument serial number (s. nameplate) manually, then enter code.</li> </ul>	For a detailed description, see chapter "Replacement of central module".
No HART communication	No central HART module	Verify by looking at nameplate: HART = -xxx5xx and -xxx6xx	Upgrade to LSCH-H1 / -H2.
	No or wrong DD (device description)	For further information see BA208e00, "HART® - Field communication with OxM223/253".	
	HART interface missing		
	Instrument not registered with HART server		
	Load too low (load > 230 Ω required)		
	HART receiver (e.g. FXA 191) not connected via load but via power supply		
	Incorrect device address (addr. = 0 for single operation, addr. > 0 for multi-drop operation)		
	Line capacitance too high		
	Line interferences		
Several devices set to same address	Set addresses correctly.	Communication not possible with several devices set to same address.	

Error	Possible cause	Tests and / or remedial measures	Equipment, spare parts, personnel
No PROFIBUS® communication	No central PA/DP module	Verify by looking at nameplate: PA = -xxx3xx /DP = xxx4xx	Upgrade to LSCP module, see chapter "Spare parts".
	Incorrect instrument software version (without PROFIBUS)	For further information, see BA209e00 "PROFIBUS PA/DP - Field communication with OxM223/253".	
	Commuwin (CW) II: Incompatible CW II and instrument software versions		
	No or incorrect DD/DLL		
	Incorrect baud rate setting for segment coupler in DPV-1 server		
	Incorrect station (master) addressed or duplicate address		
	Incorrect station (slaves) address		
	Bus line not terminated		
	Line problems (too long, cross section too small; not shielded, screen not grounded, wires not twisted)		
	Bus voltage too low (bus supply voltage typ. 24 V DC for non-Ex)		

### 9.4 Instrument specific errors

The following table helps you during the diagnosis and points to any spare parts required.

Depending on the degree of difficulty and the measuring equipment present, diagnosis is carried out by:

- Trained operator personnel
- The user's trained electrical technicians
- Company responsible for system installation/operation
- Responsible Service

Information on the exact spare part designations and on how to install these parts can be found in the "Spare parts" section.

Error	Possible cause	Tests and/or remedial measures	Execution, tools, spare parts
Device cannot be operated, display value 9999	Operation locked	Press CAL and MINUS keys simultaneously.	See "Function of keys" section.
Display dark, no light-emitting diode active	No line voltage	Check whether line voltage is present.	Electrical technician/e.g. multimeter
	Supply voltage wrong/too low	Compare actual line voltage and nameplate data.	User (data for energy supply company or multimeter)
	Connection faulty	Terminal not tightened; insulation jammed; wrong terminals used.	Electrical technician
	Device fuse defective	Compare line voltage and the nameplate data and replace fuse.	Electrical technician/suitable fuse; see drawing in "Spare parts" section.
	Power unit defective	Replace power unit, note variant.	On-site diagnosis by responsible Service, test module necessary
	Central module defective	Replace central module, note variant.	On-site diagnosis by responsible Service, test module necessary
	OLM253: ribbon cable item 310 loose or defective	Check ribbon cable, renew if necessary.	See "Spare parts" section.

Error	Possible cause	Tests and/or remedial measures	Execution, tools, spare parts
Display dark, light-emitting diode active	Central module defective (module: LSCH/LSCP)	Renew central module, note variant.	On-site diagnosis by responsible Service, test module necessary
Display is on but – No change in display and/or – Device cannot be operated	Device or module in device not correctly mounted	OLM223: reinstall insert. OLM253: remount display module.	Perform with the aid of the installation drawings in the "Spare parts" section.
	Operating system in unpermitted mode	Switch device off and then on again.	Poss. EMC problem: if this persists, check the installation or have it checked by responsible Service.
Device gets hot	Voltage wrong/too high	Compare line voltage and nameplate data.	User, electrical technician
	Power unit defective	Replace power unit.	Diagnosis only by responsible Service
Incorrect meas. cond/ MΩ and/or temperature	Transmitter module defective (module: MKIC), please first carry out tests and take measures as per the "Process errors without messages" section.	Measuring input test: – Connect resistor in place of conductivity sensor – Resistance 100 Ω at terminals 11/12 + 13 = display 0 °C	If test negative: replace module (note variant). Perform with the aid of the exploded drawings in the "Spare parts" section.
Current output, current value incorrect	Adjustment not correct	Check with installed current simulation, connect mA meter directly to current output.	If simulation value incorrect: adjustment in factory or new module LSCxx required. If simulation value correct: check current loop for load and shunts.
	Load too big		
	Shunt/short to ground in current loop		
	Incorrect mode of operation	Check whether 0–20 mA or 4–20 mA is selected.	
No current output signal	Current output stage defective (module LSCH/LSCP)	Check with installed current simulation, connect mA meter directly to current output.	If test negative: Renew central module LSCH/LSCP (note variant).
No function of additional relay	OLM253: ribbon cable item 320 loose or defective	Check ribbon cable seating, renew cable if required.	See "Spare parts" section.
Only 2 additional relays can be triggered	Relay module LSR1-2 installed with 2 relays	Upgrade to LSR1-4 with 4 relays.	User or responsible Service
Additional functions (Plus package) missing	No or incorrect release code used	If retrofitting: check whether the correct serial number was quoted when ordering the Plus package.	Handled by your supplier
	Incorrect device serial number saved in LSCH/LSCP module	Check whether serial number on the nameplate matches SNR in LSCH/LSCP (field S 8).	The serial number of the device is definitive for the Plus package.
Additional functions (Plus package and/or Chemoclean) missing after LSCH/LSCP module replaced	Replacement modules LSCH or LSCP have the <b>device</b> serial number 0000 when they leave the factory. The Plus package or Chemoclean are not enabled on leaving the factory.	In the case of LSCH/LSCP with SNR 0000, a <b>device</b> serial number can be entered once in fields E114 to E116. Then enter the release code for the Plus package and/or Chemoclean.	For a detailed description, see "Replacing central module" section.
No HART or PROFIBUS-PA-DP interface function	Incorrect central module	HART: LSCH-H1 or H2 module, PROFIBUS-PA: LSCP-PA module, PROFIBUS-DP: LSCP-DP module, see field E112.	Replace central module; user or responsible Service
	Wrong software	SW version see field E111.	SW can be modified with optoscope.
	Bus problem	Remove some devices and repeat the test.	Contact responsible Service.

## 9.5 Spare parts

Spare parts are to be ordered from your sales center responsible. Specify the order numbers listed in the chapter "Spare parts kits".

To be on the safe side, you should **always** specify the following data with your spare part orders:

- Instrument order code (order code)
- Serial number (serial no.)
- Software version where available

Refer to the nameplate for the order code and serial number.

The software version is displayed in the instrument software (see chapter "Instrument configuration") if the instrument processor system is functional.

### 9.5.1 Dismantling of panel mounted instrument

Caution!

Please note the effects on the process if the device is taken out of service!

Note!

Please refer to the diagram in Section 9.5 for the item numbers.

1. Disconnect the terminal block (item 420 b) from the rear of the device to de-energise the device.
2. Then remove the terminal blocks (item 420 a and poss. 430) from the rear of the device. Now you can disassemble the device.
3. Press in the latches of the end frame (item 340) and remove the frame from the rear.
4. Release the special screw (item 400) by turning it counter-clockwise.
5. Remove the entire electronics block from the housing. The modules are only mechanically connected and can be easily separated:
  - Simply remove the processor/display module from the front.
  - Pull out the brackets of the rear plate (item 320) slightly.
  - Now you can remove the side modules.
6. Remove the cond. transmitter (item 240) as follows:
  - Using fine side-cutting pliers, nip off the heads of the synthetic distance holders.
  - Then remove the module from above.

Assembly is the reverse of the disassembly sequence. Tighten the special screw hand-tight without a tool.



### 9.5.2 Panel mounted instrument

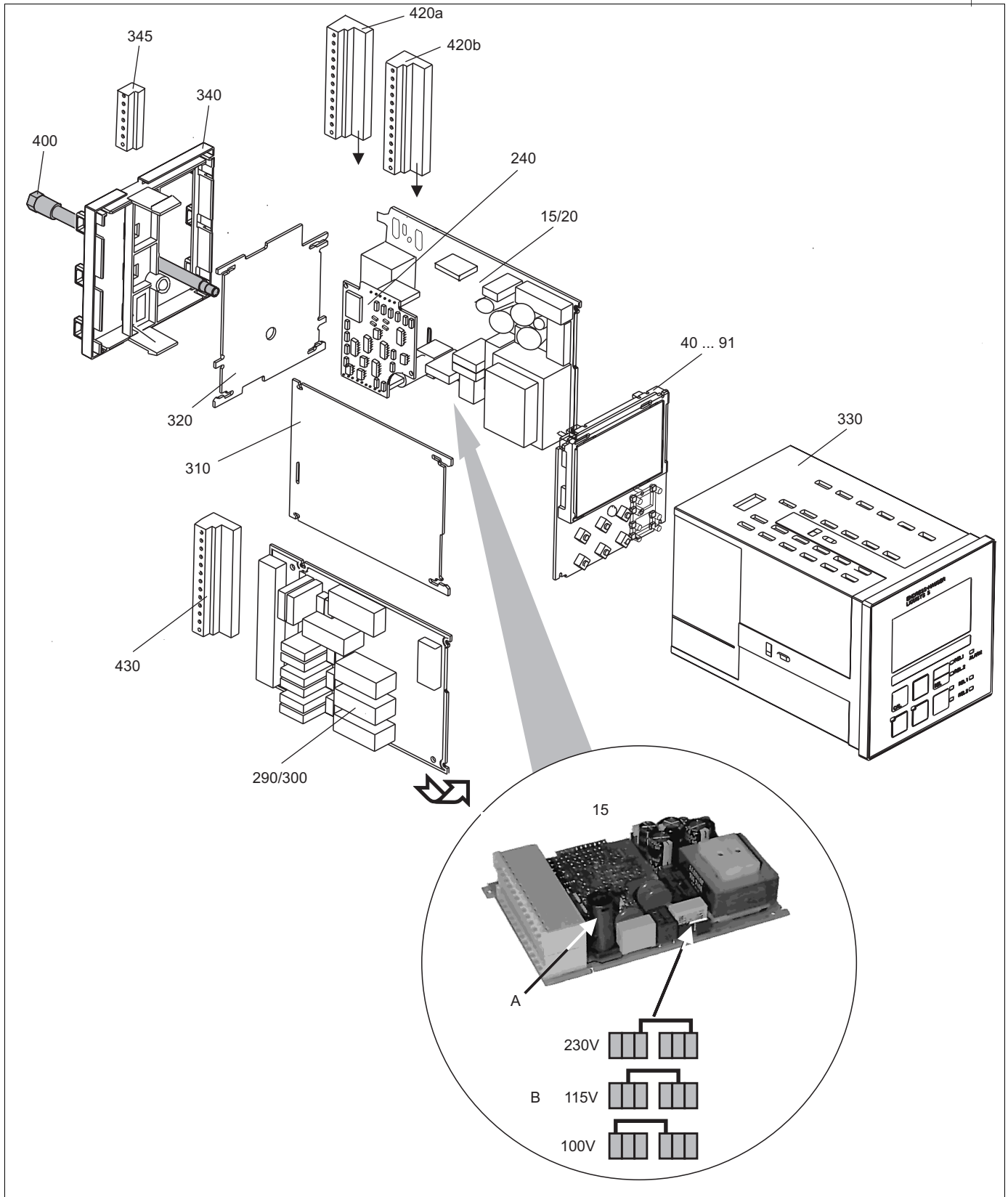

C07-OLM223xx-09-06-00-xx-001.eps

Fig. 44: Exploded view of panel mounted instrument

The exploded drawing contains the components and spare parts of the panel-mounted instrument. You can take the spare parts and the corresponding order number from the following section using the item numbers.

Item	Kit description	Name	Function/contents	Order number
15	Power unit (main module)	LSGA	100 / 115 / 230 V AC	51500317
20	Power unit (main module)	LSGD	24 V AC + DC	51500318
40	Central module cond. (controller)	LSCH-S1	1 current output	51501210
50	Central module cond. (controller)	LSCH-S2	2 current outputs	51501212
60	Central module cond. (controller)	LSCH-H1	1 current output + HART	51501213
70	Central module cond. (controller)	LSCH-H2	2 current outputs + HART	51501214
80	Central module cond. (controller)	LSCP-PA	PROFIBUS PA/no current output	51501215
90	Central module cond. (controller)	LSCP-DP	PROFIBUS DP/no current output	51502502
41	Central module ind. (controller)	LSCH-S1	1 current output	51501216
51	Central module ind. (controller)	LSCH-S2	2 current outputs	51501218
61	Central module ind. (controller)	LSCH-H1	1 current output + HART	51501219
71	Central module ind. (controller)	LSCH-H2	2 current outputs + HART	51501220
81	Central module ind. (controller)	LSCP-PA	PROFIBUS PA/no current output	51501221
91	Central module ind. (controller)	LSCP-DP	PROFIBUS DP/no current output	51502501
240	Conductivity transmitter	MKIC	Cond. + temperature input	51501206
290	Relay module	LSR1-2	2 relays	51500320
290	Relay module	LSR2-2i	2 relays + current input 4 ... 20 mA	51504304
300	Relay module	LSR1-4	4 relays	51500321
300	Relay module	LSR2-4i	4 relays + current input 4 ... 20 mA	51504305
310	Side panel		Kit with 10 parts	51502124
310, 320, 340, 400	Housing mechanical parts		Rear plate, side panel, end frame, special screw	51501076
330, 400	Housing module		Housing with front membrane, sensory tappets, gasket, special screw, tensioning dogs, connection plates and nameplates	51501075
340	End frame PROFIBUS-DP		Rear frame for PROFIBUS DP, with D-submin plug connector	51502513
345	Grounding terminal strip		PE and screening connections	51501086
420a, 420b	Terminal strip set		Complete terminal strip set, standard + HART	51501203
420a, 420b	Terminal strip set		Complete terminal strip set, PROFIBUS PA	51502126
420a, 420b	Terminal strip set		Complete terminal strip set, PROFIBUS DP	51502493
430	Terminal strip		Terminal strip for relay module	51501078
A	Fuse		Part of power unit, item 15	
B	Choice of line voltage		Position of jumper on power unit, item 15 depending on line voltage	

### 9.5.3 Dismantling of field instrument



#### Caution!

Please note the effects on the process if the device is taken out of service!



#### Note!

Please refer to the diagram in Section 9.5 for the item numbers.

To dismantle the field instrument you need the following tools:

- Standard set of screwdrivers
- Torx-screwdriver size TX 20

Proceed as follows:

1. Open and remove the cover of the connection compartment (item 420).
2. Disconnect the mains terminal (item 470) to de-energise the device.
3. Open the display cover (item 410) and loosen the ribbon cables (item 310/320) on the side of the central module (item 40 ... 91).
4. To remove the central module (item 40), loosen the screw in the display cover (item 450 b).
5. Proceed as follows to remove the electronics box (item 330):
  - Release the screws in the housing base (item 450 a) with two revolutions.
  - Then push the entire box backwards and remove it from above.
  - Make sure that module locks do not open!
  - Loosen the ribbon cables (item 310/320)
  - Bend the module locks out and remove the modules.
6. To remove the docking module (item 340), remove the screws in the housing base (item 450 c) and remove the entire module from above.
7. Proceed as follows to remove the cond. transmitter (item 240):
  - Using fine side-cutting pliers, nip off the heads of the synthetic distance sleeves.
  - Then remove the module from above.

To assemble, carefully push the modules into the trolley tracks of the electronics box and let them engage in the side box noses.



#### Note!

- Incorrect mounting is not possible. Modules inserted in the electronics box incorrectly are not operable since the ribbon cables cannot be connected.
- Make sure the cover seals are intact to guarantee IP 65 ingress protection.

### 9.5.4 Field instrument

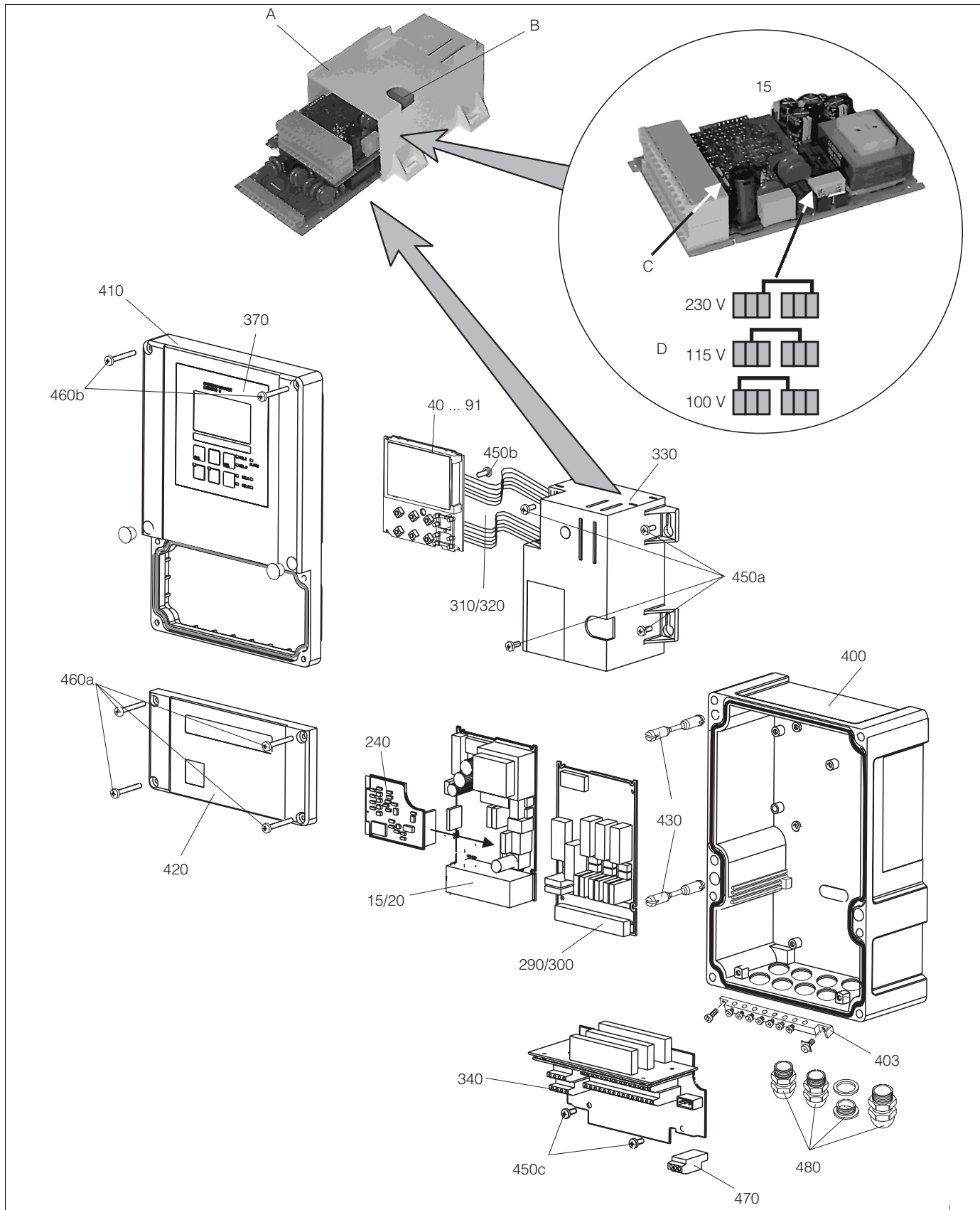

Fig. 45: Exploded drawing of field instrument

C07-OLM253xx-09-06-00-xx-001.eps

The exploded drawing contains the components and spare parts of the field device. You can take the spare parts and the corresponding order number from the following section using the item numbers.

Item	Kit description	Name	Function/contents	Order number
15	Power unit (main module)	LSGA	100 / 115 / 230 V AC	51500317
20	Power unit (main module)	LSGD	24 V AC + DC	51500318
40	Central module cond. (controller)	LSCH-S1	1 current output	51501210
50	Central module cond. (controller)	LSCH-S2	2 current outputs	51501212
60	Central module cond. (controller)	LSCH-H1	1 current output + HART	51501213
70	Central module cond. (controller)	LSCH-H2	2 current outputs + HART	51501214
80	Central module cond. (controller)	LSCP-PA	PROFIBUS PA/no current output	51501215
90	Central module cond. (controller)	LSCP-DP	PROFIBUS DP/no current output	51502502
41	Central module ind. (controller)	LSCH-S1	1 current output	51501216
51	Central module ind. (controller)	LSCH-S2	2 current outputs	51501218
61	Central module ind. (controller)	LSCH-H1	1 current output + HART	51501219
71	Central module ind. (controller)	LSCH-H2	2 current outputs + HART	51501220
81	Central module ind. (controller)	LSCP-PA	PROFIBUS PA/no current output	51501221
91	Central module ind. (controller)	LSCP-DP	PROFIBUS DP/no current output	51502501
240	Conductivity transmitter	MKIC	Cond. + temperature input	51501206
290	Relay module	LSR1-2	2 relays	51500320
290	Relay module	LSR2-2i	2 relays + current input 4 ... 20 mA	51504304
300	Relay module	LSR1-4	4 relays	51500321
300	Relay module	LSR2-4i	4 relays + current input 4 ... 20 mA	51504305
410, 420, 370, 430,	Housing cover		Display cover, front membrane, connection compartment cover, hinges, cover screws, small parts	51501068
400, 480	Housing base		Base, threaded joints	51501072
330, 340, 450	Internal housing parts		Docking assembly, empty electronics box, small parts	51501073
310, 320	Ribbon cable lines		2 ribbon cable lines	51501074
430	Hinges		2 pairs of hinges	51501069
470	Terminal strip		Terminal strip for connection to mains	51501079
420a, 420c	Terminal strip set		Terminal strip set complete for PROFIBUS DP	51502493
403	PE rail		PE connection rail for screen grounding	51501087
A	Electronics box with relay module LSR1-x (bottom) and power unit LSGA/LSGD (top)			
B	Fuse also accessible if electronics box installed			
C	Fuse		Part of power unit, item 15	
D	Choice of line voltage		Position of jumper on power unit, item 10 depending on desired line voltage	



## 9.5.5 Replacing the controller

### Note!

Generally, when a central module has been replaced, all data which can be changed are set to the factory setting.

Proceed as described below if a central module is replaced:

1. If possible, note the customised settings of the device, such as:
  - Calibration data
  - Current assignment, main parameter and temperature
  - Relay function selections
  - Limit value/controller settings
  - Cleaning settings
  - Monitoring functions
  - Interface parameters
2. Disassemble the device as explained in the "Dismantling the panel-mounted instrument" or "Dismantling the field instrument" section.
3. Use the part number on the central module to check whether the new module has the same part number as the previous module.
4. Assemble the device with the new module.
5. Start up the device again and check the basic functions (e.g. measured value and temperature display, operation via keyboard).
6. Enter the serial number:
  - Read the serial number ("ser-no.") off the nameplate of the device.
  - Enter this number in the fields E115 (year, one-digit), E116 (month, one-digit), E117 (cons. number, four-digit).
  - In the field E118, the complete number is displayed again so you can check it is correct.



### Caution!

You can only enter the serial number for modules fresh from the factory with the serial number 0000. This can only be done **once!** For this reason, make sure the number entered is correct before you confirm with ENTER!

Entry of an incorrect code will prevent the additional functions from being enabled. An incorrect serial number can only be corrected at the factory!

Press ENTER to confirm the serial number or cancel the entry to enter the number again.

7. If available, enter the release codes for the Plus Package and/or Chemoclean in the "Service" menu.
8. Check the Plus Package release (e.g. by opening the function group CHECK / Code P) or the Chemoclean function.
9. Make the customer device settings again.

## 9.6 Return

If the transmitter has to be repaired, please return it *cleaned* to the sales centre responsible. Please use the original packaging, if possible.

## 9.7 Disposal

The device contains electronic components and must therefore be disposed of in accordance with regulations on the disposal of electronic waste.

Please observe local regulations.

## 10 Technical data

### 10.1 Input

<b>Measured variable</b>	Conductivity, resistivity, temperature	
<b>Measuring range</b>	Conductivity (conductive):	0 ... 60 mS/cm (uncompensated)
	Conductivity (inductive):	0 ... 2000 mS/cm (uncompensated)
	Resistivity:	0 ... 200 M $\Omega$ ·cm
	Concentration:	0 ... 9999 (% , ppm, mg/l, TDS)
	Temperature:	-35 ... +250 °C (-31 ... +482 °F)
<b>Cable specifications</b>	Cable length (conductive):	Conductivity: max. 100 m (328.1 ft) (OYK71)
		Resistivity: max. 15 m (49.22 ft) (OYK71)
	Cable length (inductive):	max. 55 m (180.46 ft) (OLK5)
	Cable resistance OYK71:	165 $\Omega$ /km (conductivity measurement)
<b>Temperature sensors</b>	Pt 100, Pt 1000, NTC 30K	
<b>Measuring frequency</b>	Conductivity (conductive):	170 ... 2000 Hz
	Resistivity:	170 ... 2000 Hz
	Conductivity (inductive):	2000 Hz
<b>Binary inputs 1 and 2</b>	Voltage:	10 ... 50 V
	Current consumption:	Max. 10 mA
<b>Current input</b>	4 ... 20 mA, galvanically isolated	
	Load: 260 $\Omega$ for 20 mA (voltage drop 5.2 V)	

### 10.2 Output

<b>Output signal</b>	0/4 ... 20 mA, galvanically isolated	
<b>Signal on alarm</b>	2.4 or 22 mA in case of error	
<b>Load</b>	Max. 500 $\Omega$	
<b>Transmission range</b>	Conductivity:	Adjustable
	Resistivity:	Adjustable
	Concentration:	Adjustable
	Actuating variable:	Adjustable
	Temperature:	Adjustable
<b>Signal resolution</b>	Max. 700 digits/mA	

<b>Minimum spread 0 / 4 ... 20 mA signal</b>	Conductivity:	
	Meas. value 0 ... 1.999 $\mu\text{S/cm}$	0.2 $\mu\text{S/cm}$
	Meas. value 0 ... 19.99 $\mu\text{S/cm}$	2 $\mu\text{S/cm}$
	Meas. value 20 ... 199.9 $\mu\text{S/cm}$	20 $\mu\text{S/cm}$
	Meas. value 200 ... 1999 $\mu\text{S/cm}$	200 $\mu\text{S/cm}$
	Meas. value 2 ... 19.99 $\text{mS/cm}$	2 $\text{mS/cm}$
	Meas. value 20 ... 2000 $\text{mS/cm}$	20 $\text{mS/cm}$
	Resistivity:	
	Meas. value 0 ... 199.9 $\text{k}\Omega\text{-cm}$	20 $\text{k}\Omega\text{-cm}$
	Meas. value 200 ... 1999 $\text{k}\Omega\text{-cm}$	200 $\text{k}\Omega\text{-cm}$
	Meas. value 2 ... 19.99 $\text{M}\Omega\text{-cm}$	2.0 $\text{M}\Omega\text{-cm}$
	Meas. value 20 ... 200 $\text{M}\Omega\text{-cm}$	20 $\text{M}\Omega\text{-cm}$
	Concentration:	no minimum spread
	Temperature:	15 °C
<b>Insulation voltage</b>	Max. 350 $V_{\text{eff}}$ / 500 V DC	
<b>Overvoltage protection</b>	according to EN 61000-4-5	
<b>Auxiliary voltage output</b>	Output voltage:	15 V $\pm$ 0.6
	Output current:	Max. 10 mA
<b>Contact outputs (floating changeover contacts)</b>	Switching current with ohmic load ( $\cos \varphi = 1$ ):	Max. 2 A
	Switching current with inductive load ( $\cos \varphi = 0.4$ ):	Max. 2 A
	Switching voltage:	Max. 250 V AC, 30 V DC
	Switching capacity with ohmic load ( $\cos \varphi = 1$ ):	Max. 500 VA , 60 W DC
	Switching capacity with inductive load ( $\cos \varphi = 0.4$ ):	Max. 500 VA
<b>Limit contactor</b>	Pick-up/drop-out delay	0 ... 2000 s
<b>Controller</b>	Function (adjustable):	Pulse length/pulse frequency controller
	Controller behaviour:	P, PI, PD, PID
	Control gain $K_p$ :	0.01 ... 20.00
	Integral action time $T_i$ :	0.0 ... 999.9 min
	Derivative action time $T_v$ :	0.0 ... 999.9 min
	Period length for pulse length controller:	0.5 ... 999.9 s
	Frequency for pulse frequency controller:	60 ... 180 $\text{min}^{-1}$
	Basic load:	0 ... 40% of max. set value
<b>Alarm</b>	Function (switchable):	Latching/momentary contact
	Alarm threshold adjustment range:	Conductivity, resistivity, concentration, temperature, USP: entire measuring range
	Alarm delay:	0 ... 2000 s (min)

### 10.3 Power supply

<b>Supply voltage</b>	Depending on ordered version: 100/115/230 V AC +10/-15 %, 48 ... 62 Hz 24 V AC/DC +20/-15 %
<b>Power consumption</b>	Max. 7.5 VA
<b>Mains fuse</b>	Fine-wire fuse, semi-delay 250 V/3.15 A

### 10.4 Performance characteristics

<b>Measured value resolution</b>	Temperature:	0.1 °C
<b>Maximum measured error<sup>1</sup></b>	Display – Conductivity: – Resistivity: – Temperature:	Max. 0.5 % of measured value ± 4 digits Max. 0.5 % of measured value ± 4 digits Max. 1.0 % of scope of measuring range
	Signal output – Conductivity: – Resistivity: – Temperature:	Max. 0.75 % of current output range Max. 0.75 % of current output range Max. 1.25 % of current output range
<b>Repeatability<sup>1</sup></b>	Conductivity:	Max. 0.2 % of measured value ± 2 digits
	Resistivity:	Max. 0.2 % of measured value ± 2 digits
<b>Temperature compensation</b>	Range:	-35 ... +250 °C (-31 ... +482 °F)
	Types of compensation:	uncompensated, linear, NaCl, table; conductive only: ultrapure water (NaCl)
<b>Reference temperature</b>	25 °C (77 °F); adjustable for the compensation of the medium temperature	
<b>Temperature offset</b>	±5 C	

1) In accordance with IEC 746-1, for nominal operating conditions

### 10.5 Environment

<b>Ambient temperature range</b>	-10 ... +55 C (+14 ... +131 °F)	
<b>Ambient temperature limits</b>	-20 ... +60 C (-4 ... +140 °F)	
<b>Storage temperature</b>	-25 ... +65 C (-13 ... +149 °F)	
<b>Electromagnetic compatibility</b>	Interference emission and interference immunity as per EN 61326: 1997 / A1: 1998	
<b>Overvoltage protection</b>	As per EN 61000-4-5:1995	For outputs, binary inputs and current input
<b>Degree of protection</b>	Panel-mounted instrument:	IP 54 (front), IP 30 (housing)
	Field device:	IP 65
<b>Relative humidity</b>	10 ... 95%, not condensating	

## 10.6 Mechanical construction

<b>Design/dimensions</b>	Panel-mounted instrument:	L x W x D: 96 x 96 x 145 mm (3.78" x 3.78" x 5.71") Installation depth: approx. 165 mm (6.50")
	Field device:	L x W x D: 247 x 170 x 115 mm (9.72" x 1.70" x 4.53")
<b>Weight</b>	Panel-mounted instrument:	Max. 0.7 kg (1.5 lb)
	Field device:	Max. 2.3 kg (5.1 lb)
<b>Material</b>	Panel-mounted instrument housing:	Polycarbonate
	Field housing:	ABS PC Fr
	Front membrane:	Polyester, UV-resistant
<b>Terminals</b>	Cable cross-section:	max. 2.5 mm <sup>2</sup>

# 11 Appendix

<p>Function group <b>CALIBRATION</b> C</p>	<p>Calibration Instf = Installation factor C1 (3)</p>	<p>Calibration temperature entry (MTC) 25.0 °C -35.0 ... +250.0 °C C131</p>	<p>Entry of a <math>\alpha</math> value of calibration solution 2.10 %/K 0.00 ... 20.00 %/K C132</p>	<p>Entry of correct conductivity value of calibration solution Current meas. value C133 0.0 <math>\mu</math>S/cm ... 9999 mS/cm</p>	<p>Display of calculated installation factor 1.0 0.10 ... 5.0 C134</p>	<p>Calibration status is displayed o.k.; E--- C135</p>	
	<p>Cellc = Cell constant C1 (2)</p>	<p>Calibration temperature entry (if B1 = fixed) 25.0 °C -35.0 ... +250.0 °C C121</p>	<p>Entry of a <math>\alpha</math> value of calibration solution 2.10 %/K 0.00 ... 20.00 %/K C122</p>	<p>Entry of correct conductivity value of calibration solution Current meas. value C123 0.0 mS/cm ... 9999 mS/cm</p>	<p>Display of calculated cell constant 0.0025 ... 99.99 1/cm C124</p>	<p>Calibration status is displayed o.k.; E--- C125</p>	
	<p>AirS = Airset C1 (1)</p>	<p>Residual coupling Start calibration Current meas. value C111</p>	<p>Display of residual coupling (Airset) 0.0 <math>\mu</math>S C112</p>	<p>Calibration status is displayed o.k. E--- C113</p>	<p>Store calibration results yes; no; new C114</p>		
<p>MEAS. VALUE DISPLAY with TEMPERATURE DISPLAY in °C</p>	<p>Temperature display in °F</p>	<p>Temperature display suppressed</p>	<p>Measured value display Current output in %</p>	<p>Measured value display Current output in mA</p>	<p>Uncompensated measured value is displayed</p>		
	<p>1st error is displayed (if present)</p>	<p>Other errors are displayed (up to 10 errors)</p>					
<p>Function group <b>SETUP 1</b> A</p>	<p>Selection of operation mode cond = conductive ind = inductive MOhm = resistance conc = concentration A1</p>	<p>Selection of unit displayed ppm; mg/l; %; TDS; none (% only if A1 = conc) A2</p>	<p>Display format selection (if A1 = conc) XX.xx; X.xxx; XXX.x; XXXX A3</p>	<p>Selection of unit displayed auto; <math>\mu</math>S/cm; mS/cm; S/cm; <math>\mu</math>S/m; mS/m; S/m auto<math>\Omega</math>; k<math>\Omega</math>/cm; M<math>\Omega</math>/cm; k<math>\Omega</math>/m (omitted if A1 = conc) A4</p>	<p>Entry of cell constant cond / ind / MOhm 1.000 / 1.98 / 0.01 1/cm 0.0025 ... 99.99 1/cm for cond; ind; MOhm A5</p>	<p>Entry of cable resistance (if A1 = cond) 0.00 <math>\Omega</math> 0.00 ... 99.99 <math>\Omega</math> A6</p>	
<p>Function group <b>SETUP 2</b> B</p>	<p>Selection of temperature measurement Pt100 Pt1k (= Pt 1000) NTC30 (= NTC 30 k<math>\Omega</math>) fixed B1</p>	<p>Selection of temperature compensation type none lin = linear NaCl = common salt Pure = pure water NaCl PureH = pure water HCl Tab = table B2</p>	<p>Entry of <math>\alpha</math> value (if B2 = linear) 2.10 %/K 0.00 ... 20.00 %/K B3</p>	<p>Entry of correct process temperature (if B1 = fixed) 25.0 °C -35.0 °C ... +250.0 °C B4</p>	<p>Temperature sensor calibration (omitted if B1 = fixed) Display of actual value -35.0 ... +250.0 °C B5</p>	<p>Enter temperature difference (omitted if B1 = fixed) Current offset -5.0 ... 5.0 °C B6</p>	
<p>Function group <b>CURRENT INPUT</b> Z</p>	<p>Cont. switch-off by current input Off; Input Z1</p>	<p>Delay for cont. switch-off current input 0 s 0 ... 2000 s Z2</p>	<p>Delay for cont. switch-on current input 0 s 0 ... 2000 s Z3</p>	<p>Switch-off limit value for current input 50% 0 ... 100% Z4</p>	<p>Switch-off direction for current input Low; High Z5</p>	<p>Feedforward control to PID controller Off; lin = linear Z6</p>	
		<p>Characteristic selection table O3 (3)</p>	<p>Table option selection read edit O331</p>	<p>Entry of number of value pairs in table 1 1 ... 10 O332</p>	<p>Selection of value pair in table 1 1 ... number of value pairs assign O333</p>		
		<p>sim = simulation O3 (2)</p>	<p>Simulation value entry current value 0 ... 22.00 mA O321</p>				
<p>Function group <b>CURRENT OUTPUT</b> O</p>	<p>Current output selection Out1; Out2 O1</p>	<p>Select measured variable for 2nd current output °C; mS/cm; Contr O2</p>	<p>lin = linear O3 (1)</p>	<p>Current range selection 4-20 mA; 0-20 mA O311</p>	<p>Entry of 0/4 mA value 0 <math>\mu</math>S/cm / 0 k<math>\Omega</math>/cm / 0 % / 0 °C entire measuring range O312</p>	<p>Entry of 20 mA value 2000 mS/cm / 500 k<math>\Omega</math>/cm / 9999 % / 150.0 °C entire measuring range O313</p>	
<p>Function group <b>ALARM</b> F</p>	<p>Select contact type Stead = steady contact; Fleat = fleeting contact F1</p>	<p>Select alarm delay unit s; min F2</p>	<p>Alarm delay 0 s (min) 0 s ... 2000 s (min) (depends on F2) F3</p>	<p>Error current setting 22 mA 2.4 mA F4</p>	<p>Error number selection 1 1 ... 255 F5</p>	<p>Set alarm contact to be effective yes; no F6</p>	
<p>Function group <b>CHECK</b> P</p>	<p>Switch polarisation detection on or off off; on P1</p>	<p>Set alarm threshold Off; Low; High; Lo+Hi; Lo; Hi; LoHi! P2</p>	<p>Enter alarm delay 0 s (min) 0 ... 2000 s (min) P3</p>	<p>Set lower alarm threshold 0 <math>\mu</math>S/cm 0 ... 9999 mS/cm P4</p>	<p>Set upper alarm threshold 9999 <math>\mu</math>S/cm 0 ... 9999 mS/cm P5</p>	<p>Select process monitoring Off; AC; CC; AC+CC AC; CC; ACCC! P6</p>	

Store calibration results
yes; no; new <b>C136</b>

Store calibration results
yes; no; new <b>C126</b>

Entry of measured value damping
1 (no damping) 1 ... 60 <b>A7</b>

Entry of reference temperature
25 °C -35 ... 250 °C <b>B7</b>

Feedforward control = 1 at
50% 0 ... 100% <b>Z7</b>

x value entry (measured value)
0 µS/cm / 0 kΩ·cm / 0 % / 0 °C entire measuring range <b>O334</b>

y value entry (current value)
0.00 mA 0 ... 20.00 mA entire measuring range <b>O235</b>

Table status ok
yes; no <b>O236</b>

--

Field for customer settings

Activate error current for previously set error
no; yes <b>F7</b>

Automatic start of cleaning function
no; yes (not always displayed, see error messages) <b>F8</b>

Select "next error" or return to menu
next = next error; ←-R <b>F9</b>

Set max. perm. period for lower limit exceeded
60 min 0 ... 2000 min <b>P7</b>

Set max. perm. period for upper limit exceeded
120 min 0 ... 2000 min <b>P8</b>

Set monitoring value
1000 µS/cm 0 ... 9999 mS/cm <b>P9</b>

Limit contactor configuration	EP PW	R2 (7)	Function of R2 (7) Switch off or on Off On R271	Entry of alarm threshold (switch-on point) 80 % 0.0 ... 100.0 % R272		Pickup delay entry 0 0 ... 2000 s R274	
	USP	R2 (6)	Function of R2 (6) Switch off or on Off On R261	Entry of alarm threshold (switch-on point) 80 % 0.0 ... 100.0 % R262		Pickup delay entry 0 0 ... 2000 s R264	
	Clean = Chemoclean (only with rel. 3)	R2 (5)	Function of R2 (5) Switch off or on Off; On R251	Start pulse selection Int = internal ext = external +ext = internal + external +stp = internal, suppr. by ext. R252	Entry of pre-rinse time 20 s 0 ... 999 s R253	Entry of cleaning time 10 s 0 ... 999 s R254	
	Timer	R2 (4)	Function of R2 (4) Switch off or on Off; On R241	Rinse time setting 30 s 0 ... 999 s R242	Pause time setting 360 min 1 ... 7200 min R243	Set minimum pause time 120 min 1 ... 3600 min R244	
	PID controller	R2 (3)	Function of R2 (3) Switch off or on Off; On; Basic; PID+B R231	Entry of set point 0 µS/cm / 0 kΩ·cm / 0 % entire meas. range R232	Entry of control gain Kp 1.00 0.01 ... 20.00 R233	Entry of integral action time Tn (0.0 = no I component) 0.0 min 0.0 ... 999.9 min R234	
LC °C = T limit contactor		R2 (2)	Function of R2 (2) Switch off or on Off; On R221	Entry of switch-on temperature 250.0 °C -35.0 ... +250.0 °C R222	Entry of switch-off temperature 250.0 °C -35.0 ... +250.0 °C R223	Pickup delay setting 0 s 0 ... 2000 s R224	
	LC PV = cond. limit contactor	R2 (1)	Function of R2 (1) Switch off or on Off; On R211	Select contact switch-on point 9999 mS/cm / 200 MΩ·cm / 9999 % entire meas. range R212	Select contact switch-off point 9999 mS/cm / 200 MΩ·cm / 9999 % entire meas. range R213	Pickup delay setting 0 s 0 ... 2000 s R214	
Function group RELAY	Select contact to be configured Rel1; Rel2; Rel3; Rel4 R	R1					
Function group ALPHA TABLE	Table option selection read edit T	T1	Entry of number of table value pairs 1 1 ... 10 T2	Selection of table value 1 1 ... number of table value pairs assign T3	Entry of temperature value (x value) 0.0 °C -35.0 ... +250.0 °C T4	Entry of temperature coefficient α (y value) 2.10 %/K 0.00 ... 20.00 %/K T5	Table status o.k. yes; no T6
Function group CONCENTRATION	Selection of concentration curve for calculation of display value Curve 1 ... 4 K	K1	Selection of table to be edited 1 1 ... 4 K2	Table option selection read edit K3	Set number of value pairs 1 1 ... 10 K4	Select value pair 1 1 ... number of value pairs in K4 K5	Entry of uncompensated conductivity value 0.0 µS/cm 0.0 ... 9999 mS/cm K6
Function group SERVICE	Language selection ENG; GER ITA; FRA ESP; NEL S	S1	Hold configuration - none = no hold - s+c = during setup and calibration - CAL = during calibration - Setup = during setup S2	Manual hold off; on S3	Entry of hold dwell period 10 s 0 ... 999 s S4	Entry of SW upgrade release code (plus package) 0000 0000 ... 9999 S5	Entry of SW upgrade release code Chemoclean 0000 0000 ... 9999 S6
Module selection	Relay	E1 (4)	Software version SW version E141	Hardware version HW version E142	Serial number is displayed E143	Module name is displayed E144	
	MainB = mainboard	E1 (3)	Software version SW version E131	Hardware version HW version E132	Serial number is displayed E133	Module name is displayed E134	
	Trans = transmitter	E1 (2)	Software version SW version E121	Hardware version HW version E122	Serial number is displayed E123	Module name is displayed E124	
	Contr = controller	E1 (1)	Software version SW version E111	Hardware version HW version E112	Serial number is displayed E113	Module name is displayed E114	
Function group SERVICE 2							
Function group INTERFACE	Entry of address HART: 0 ... 15 or Profibus 1 ... 126 I	I1	Tag description @@@@@@@ I2				

Dropout delay entry  
 0  
 0 ... 2000 s  
**R275**

Dropout delay entry  
 0  
 0 ... 2000 s  
**R265**

Entry of post-rinse time  
**20 s**  
 0 ... 999 s  
**R255**

Number of repeat cycles  
**0**  
 0 ... 5  
**R256**

Set interval between two cleaning cycles (pause time)  
**360 min**  
 1 ... 7200 min  
**R257**

Set minimum pause time  
**120 min**  
 1 ... R357 min  
**R258**

Number of cleaning cycles without cleaning agent  
**0**  
 0 ... 9  
**R259**

Entry of derivative action time Tv (0.0 = no D component)  
**0.0 min**  
 0.0 ... 999.9 min  
**R235**

Selection of control characteristic  
 dir = direct;  
 inv = inverted  
**R236**

Selection  
 len = pulse length  
 freq = pulse frequency  
 curr = current input 2  
**R237**

Entry of pulse interval  
**10.0 s**  
 0.5 ... 999.9 s  
**R238**

Entry of max. pulse frequency  
**120 1/min**  
 60 ... 180 1/min  
**R239**

Entry of min. ON time  
 t<sub>on</sub>  
**0.3 s**  
 0.1 ... 5.0 s  
**R2310**

Enter basic load  
**40%**  
 0 ... 40%  
**R2311**

Dropout delay setting  
**0 s**  
 0 ... 2000 s  
**R225**

Setting of alarm threshold  
**250.0 °C**  
 -35.0 ... +250.0 °C  
**R226**

Display of LC status  
**MAX**  
**MIN**  
**R227**

Dropout delay setting  
**0 s**  
 0 ... 2000 s  
**R215**

Setting of alarm threshold (as an absolute value)  
**9999 mS/cm / 200 MK/cm / 9999 %**  
 entire meas. range  
**R216**

Display of LC status  
**MAX**  
**MIN**  
**R217**

Entry of associated concentration value  
**0.00 %**  
 0 ... 99.99 %  
**K7**

Entry of associated temperature value  
**0.0 °C**  
 -35.0 ... 250.0 °C  
**K8**

Table status o.k.  
**yes; no**  
**K9**

Order number is displayed  
**S7**

Serial number is displayed  
**S8**

Reset instrument (restore default values)  
**no;**  
 Sens = sensor data;  
 Facty = factory settings  
**S9**

Perform instrument test  
**no;**  
 Displ = display  
**S10**

# Index

<b>A</b>	
Access codes	26
Accessories	75
Alarm	43
Alarm contact	20
Automatic mode	25
<b>C</b>	
Calibration	67
Check	44
Conductive sensors	73
Inductive sensors	74
Checking	
Connections	20
Function	28
Installation	14
Chemoclean function	51
Cleaning	
pH/Redox sensors	71
Transmitter	70
Commissioning	4, 28
Communication	66
Concentration measurement	61
Connection diagram	16
Controller replacement	93
Current input	37
Current outputs	40
<b>D</b>	
Declaration of conformity	7
Designated use	4
Diagnosis code	79
Dismantling	
Field instrument	90
Panel mounted instrument	87
Display	21
Disposal	93
<b>E</b>	
Electrical connection	16
Electrical icons	5
EMC	4
Environment	96
EP	52
European Pharmacopoeia	52
<b>F</b>	
Factory settings	29
Field device connection	17
Freezing of outputs	27
<b>H</b>	
Hold function	27, 64
<b>I</b>	
Icons	
Electrical	5
Safety symbols	5
Incoming acceptance	9
Input	94
Installation	4, 8–9, 11
Instrument specific errors	85
Interfaces	66
<b>K</b>	
Key assignment	23
<b>L</b>	
Limit contactor	47
<b>M</b>	
Maintenance	70
Entire measuring point	70
Manual mode	25
Measuring cable and sensor connection	18
Measuring system	8
Mechanical construction	97
Menu structure	27
<b>O</b>	
Operating elements	22
Operating modes	26
Operation	4
Display	21
Operating concept	25
Operating elements	22
Operational safety	4
Optoscope	74
Ordering information	6
Output	94

**P**

P controller	48
PD controller	48
Performance characteristics	96
PI controller	48
PID controller	48
Plus package	6
Polarisation detection	44
Post mounting	12
Power supply	96
Process specific errors	82
Product structure	6

**Q**

Quick commissioning	30
Quick setup	30
Quick start-up	30

**R**

Relay contact configuration	47
Replacement of controller	93
Return	5, 93

**S**

Safety icons	5
Scope of delivery	7
Service	64
Service 2	65
Setup 1 (conductivity)	33
Setup 2 (temperature)	34
Simulation of conductive sensors	71
Simulation of inductive sensors	73
Spare parts	87
Storage	9
Switching on	28
Symbols	5
System configuration	33
System error messages	79

**T**

Technical data	94
Temperature compensation	
linear	34
NaCl	34
with table	35
Temperature compensation with table	60
Timer for cleaning function	50
Transport	9
Trouble-shooting	79
Instructions	79
Instrument specific errors	85
Process specific errors	82
System error messages	79

**U**

United States Pharmacopeia	52
Use	
designated	4
USP	52

**W**

Wall mounting	11
Wiring	15

